

# Farmington City & USWAC Preferred BMP List For Permitted Construction Sites

Adopted January 1, 2025  
Revised December 19, 2024

# Introduction

The operator is responsible for selecting effective site-specific Best Management Practices (BMPs) for erosion and sediment control as well as pollution prevention operations according to the site's unique current conditions and the conditions that will occur throughout construction. A qualified person (as described in section 7.2 of the Construction General Permit, and section 4 of the Common Plan Permit) should evaluate the site to ensure the selected BMP is suitable and may need to consider a series of BMPs based on site conditions and construction operations. Conditions such as slope, proximity to water, soil type, infiltration rate, feasibility, etc. should all be considered.

BMPs that do not meet their performance criteria can result in oversight authority notice of Storm Water Pollution Prevention Plan (SWPPP) violation(s) and potential enforcement.

## Purpose

The purpose of the State Preferred BMP List is to meet the requirements of Utah Code 19-5-108.3. Each MS4 in the State of Utah will select which BMPs from this Preferred BMP List document are acceptable for use within that jurisdiction at permitted construction sites.

## Applicability

This Preferred BMP List document shall be applicable to all sites that require regulation under the General Permit for Storm Water Discharges from Construction Activities (CGP) and the Common Plan Permit (CPP).

The USWAC Preferred BMPs are intended to be installed and maintained specifically as described. The operator or SWPPP agent is responsible for choosing BMPs that are applicable and will be effective at containing and managing the site's unique exposures and construction operations. The USWAC Preferred BMP List does not contain all BMPs for every situation or imply that all Preferred BMPs are agreeable to the operator.

When necessary, the operator or SWPPP agents may need to use BMPs not found in the USWAC BMP Preferred List. Where this is the case, a BMP Template is provided as the basis to describe the alternative BMP. In addition to BMPs not covered with the preferred list, the operator or SWPPP agents are invited to modify any of the USWAC BMPs to manage project exposures and operations. However, in both cases the alternative BMPs must be designed to satisfy or exceed the minimum performance

criteria. The operator or SWPPP agents must submit modified or alternative BMPs to the oversight authority for review.

Stormwater pollution control requirements are intended to be proactive and implemented on a year-round basis. Appropriate pollution control includes both erosion control and sediment mitigation as well as track out controls, non-stormwater discharge and waste management, and material pollution BMPs. Some BMPs can be implemented as a stand-alone device while others can be combined to improve effectiveness and compliance.

## Reporting

The CGP and CPP require operators to conduct inspections of storm water pollution prevention controls and keep record of these inspections. The GCP/ CPP report requirements are to demonstrate that selected BMPs are effective at controlling sources of storm water pollution. The report must include actions taken to maintain, repair, or install new BMPs as needed to fulfill the pollution prevention plan created for the site. The DEQ has provided a SWPPP inspection form for operators to utilize to record this minimum information as well as record actions taken to correct issues. See SWPPP Inspection Form.

Utah State Code 19-05-108.3 requires that operators submit “electronic site inspections” which is defined as “geo-located and time-stamped photos taken, evaluated, and submitted electronically by the applicant to the municipal system.” To guide the operator in fulfilling this additional requirement, an *Electronic Site Inspection Guide* document has been created and is accessible via the hyperlink and is found towards the bottom of the webpage.

It is important that the BMPs in the photos support the operator’s SWPPP inspection report and represent the condition of each BMP. BMPs (either sourced from this preferred list or added by the operator or SWPPP agents) that do not meet the installation, maintenance and performance criteria specified must be corrected to achieve compliance with the site specific SWPPP and CGP/ CPP. After the BMP is corrected, provide a description of how the BMP was corrected and the date the correction was made in the SWPPP Inspection report. Provide adequate geo-located and time-stamped photo(s) that support the correction action. If applicable, also address any deficiencies noted by the oversight authority within the established deadlines provided in the oversight inspection report. For guidance in which case corrective actions versus routine maintenance must be reported, refer to the CGP/ CPP for specifications.

## TABLE OF CONTENTS

<b>Introduction .....</b>	<b>2</b>
<b>Purpose.....</b>	<b>2</b>
<b>Applicability.....</b>	<b>2</b>
<b>Reporting .....</b>	<b>3</b>
<b>Template for Adding an Alternate BMP (Operator Version) .....</b>	<b>6</b>
<b>BMP 1- Portable Toilet on Pervious Surface .....</b>	<b>8</b>
<b>BMP 2- Pavement Mounted Portable Toilet .....</b>	<b>10</b>
<b>BMP 3- Curb Sedimentation Trap.....</b>	<b>12</b>
<b>BMP 4- Concrete Washout Pan .....</b>	<b>14</b>
<b>BMP 5- Concrete Washout Ground Fixed Systems .....</b>	<b>17</b>
<b>BMP 6- Small Concrete Management Operations .....</b>	<b>22</b>
<b>BMP 7- Pavement Saw Cutting-Wet .....</b>	<b>24</b>
<b>BMP 8- Pavement Saw Cutting-Dry .....</b>	<b>26</b>
<b>BMP 9- Area Drain Filtration.....</b>	<b>27</b>
<b>BMP 10- Rock Check Dam for Channels.....</b>	<b>30</b>
<b>BMP 11- Straw Wattle Check Dam for Channels .....</b>	<b>34</b>
<b>BMP 12- Culvert Sediment Barrier.....</b>	<b>37</b>
<b>BMP 13- Silt Fence.....</b>	<b>39</b>
<b>BMP 14- Earth Berm Barrier.....</b>	<b>41</b>
<b>BMP 15- Filter Tubes on Slopes .....</b>	<b>43</b>
<b>BMP 16- Drop Inlet Bag with Overflow.....</b>	<b>46</b>
<b>BMP 17- Gravel Bag Curb Inlet Protection.....</b>	<b>48</b>
<b>BMP 18- Gutter Dam.....</b>	<b>50</b>
<b>BMP 19 - Inlet Filter with Gutter Dam Combo .....</b>	<b>52</b>
<b>BMP 20- Solid Waste Management .....</b>	<b>54</b>
<b>BMP 21- Chemical/Hazardous Materials Management.....</b>	<b>56</b>
<b>BMP 22- Onsite Equipment Fueling.....</b>	<b>58</b>
<b>BMP 23- Water Bars .....</b>	<b>60</b>
<b>BMP 24- Portable Sediment Tank.....</b>	<b>62</b>
<b>BMP 25 - Sediment Basin .....</b>	<b>64</b>



**BMP 26- Rock Track Out Pad .....67**

**BMP 27- Wheel Wash.....69**

**BMP 28 - Parking Pad & Supplier Access .....71**

**BMP 29 - Manual Mud Removal .....73**

**BMP 30 - Track Vehicle Crossing .....75**

**BMP 31 - Street Sweeping .....77**

**BMP 32 - Fugitive Dust Control Plan .....78**

**BMP 33 - Vegetation Removal Phasing .....79**

**BMP 34 - Final Stabilization .....80**

**BMP 35 - Stockpile Management .....82**

**BMP 36 - Construction Dewatering Retention .....83**

**BMP 37 - Construction Dewatering Water Truck .....84**

**BMP 38 - Construction Dewatering DEQ Permit Required .....85**

...

## Template for Adding an Alternate BMP (Operator Version)

“Operators are invited to use an alternative BMP or modify a BMP from the USWAC Preferred List so long as the BMP has the same performance criteria or better as the preferred BMP. Any deviations from the preferred BMP installation and use parameters must be reviewed and accepted by the oversight authority.”

### [BMP # - Title]

Replace all blue text in brackets with BMP specific data. Then delete any remaining unnecessary blue instructional text.

[Insert the BMP detail drawing specific to the proprietary device you will use. It should illustrate the structure of the BMP, installation requirements, and any typical variances due to site conditions. ]

[IMAGE]

### **APPLICATION**

- [Describe specifically when and where this BMP will be used on site]

### **INSTALLATION/USE PROCEDURES**

- [Describe how this BMP should be installed or how it should be practiced]
- [Describe further so that it is very clear, such as minimum length of structure, etc.]

### **BMP MODIFICATION OR REPLACEMENT JUSTIFICATION**

Use only one of the two following bullets

- This BMP is replacing or augmenting [list the preferred BMP that is being replaced] OR
- This BMP is being added and implemented as the conditions or operations cannot be adequately managed by a BMP from the Farmington City & USWAC Preferred List.

### **MAINTENANCE/MANAGEMENT**

- [Add maintenance criteria for proper BMP performance]
- [Describe how the BMP should look or function during an inspection]
- [Describe when maintenance is necessary]
- [Describe when replacement is necessary]
- [Describe when no action is needed]

### **PERFORMANCE**

- [Describe performance expectations of the alternative BMP. This includes how it protects water resources, manages hazards, and limits public complaints]

### **GENERAL**

- [Include other information, direction, instruction, and BMP criteria that does not fit well into the other categories.]

**REFERENCE**

- [CGP and Federal Regulations sections, numbers, link to proprietary documentation, etc.]

## BMP 1- Portable Toilet on Pervious Surface

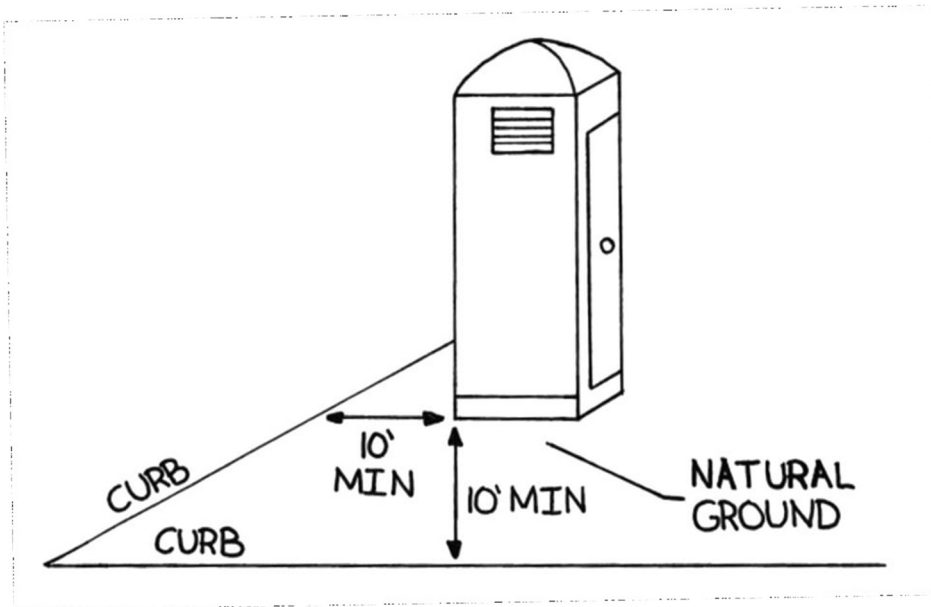

### **APPLICATION**

- Provide temporary sanitary facilities when permanent facilities are too far from activities or are unavailable.

### **INSTALLATION/USE PROCEDURE**

- Locate portable toilets away from waters of the state, and at least 10 feet from any storm water conveyance, inlet, curb and gutter, or conduit to a waterway.
- Wherever possible, locate portable toilet upon natural ground and not on impervious surfaces such as asphalt, concrete, or similar
- Prepare a level surface and provide clear access to the toilet(s) for servicing and for on-site personnel
- Wherever possible, locate a portable toilet next to track out pad or provide gravel access pad for maintenance pick up to reduce occurrence of mud track out by service provider.
- Secure portable toilets to prevent tipping e.g. stakes, tie downs, etc.

### **OPERATOR BMP MODIFICATION OR REPLACEMENT**

- Operator is invited to propose an alternative BMP or modify this preferred BMP. The proposed BMP must match or exceed performance requirements as this preferred BMP. Any deviations from this preferred BMP must be reviewed and accepted by the oversight authority.
- Submit BMP modifications or replacements to the oversight authority for review; including but not limited to; Proprietary system literature, modified illustrations, any operation procedures and maintenance adjustments, etc.
- Also see BMP 2- Portable Toilet on Pavement



### **MAINTENANCE/MANAGEMENT**

- Portable toilets should be maintained in good working order by licensed service
- Portable toilets should be inspected daily to detect any leaks
- Damaged toilets must be repaired/replaced immediately
- All waste must be deposited in the sanitary sewer system for treatment with appropriate agency approval
- Implement spill BMP immediately upon spill incident
- If track out from the service provider occurs, debris must be removed as soon as practicable.

### **PERFORMANCE**

- A portable toilet is expected to contain human waste with zero exposure to storm water.
- A successful portable toilet is clean, effective, and is processed by the appropriate licensed facility.

### **REFERENCE**

- Construction General Storm Water Permit (CGP) 2.3.3(f)
- Common Plat Permit (CPP) 2.4.4

## BMP 2- Pavement Mounted Portable Toilet



Picture for concept purpose only

### **APPLICATION**

- Use portable toilets on pavement only for projects without pervious staging areas. Usually projects within existing rights-of-way.
- Do not install portable toilets on pavement when private property is expected to be used. Generally, portable toilets installed on pavement are not acceptable for commercial and residential projects.

### **INSTALLATION/USE PROCEDURE**

- When near inlets, always locate portable toilets downstream of inlets. Identify on SWPPP BMP map.
- Place portable toilet on a surface no steeper than 2% grade.
- Attach portable toilet contractor illustrations, service and any maintenance information. For ground mount toilets provide each corner with 50# weights or as specified by the service contractor. For trailer mounted systems, provide a plan for securing the trailer as specified by the service contractor.
- Provide secondary containment. Submit for oversight authority review. A gutter dam BMP is a good choice.
- Obtain private or public right of way encroachment permit (or local equivalent) when required by the local authority.
- Attach a copy of the portable toilet manufacturer's maintenance literature.
- Ensure the spill prevention program includes containment materials and protocols for potential portable toilet spills.

- Ensure maintenance personnel and site workers involved in site operations understand BMP requirements.

### **OPERATOR BMP MODIFICATION OR REPLACEMENT**

- Operator is invited to propose an alternative BMP or modify this preferred BMP. The proposed BMP must match or exceed performance requirements as this preferred BMP. Any deviations from this preferred BMP must be reviewed and accepted by the oversight authority.
- Submit BMP modifications or replacements to the oversight authority for review; including but not limited to; Proprietary system literature, modified illustrations, any operation procedures and maintenance adjustments, etc.

### **MAINTENANCE/MANAGEMENT**

- Inspect BMP location corresponds with SWPPP BMP map. Locations are often dynamic for projects within rights-of-way.
- Inspect maintenance per manufacturer requirements
- Inspect for leaks and tank levels
- Inspect anti-tipping system

### **PERFORMANCE**

- A portable toilet is expected to contain human waste with zero exposure to storm water.
- A successful portable toilet is clean, effective, and is processed by the appropriate licensed facility.

### **REFERENCE:**

- CGP 2.3.3(f), 2.4.4
- CPP 2.4.4

## BMP 3- Curb Sedimentation Trap

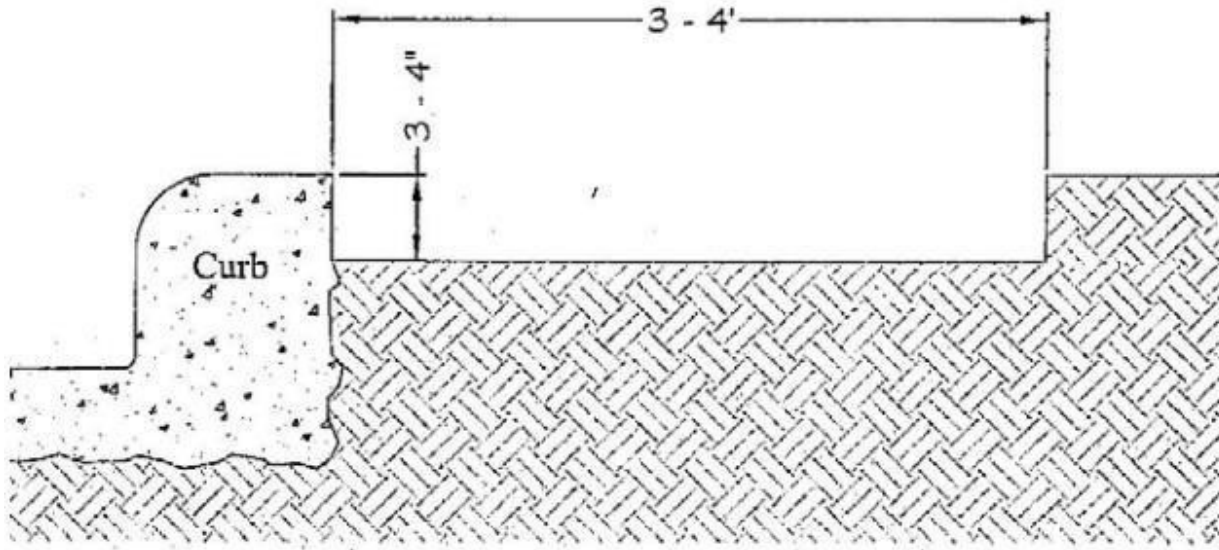

### **APPLICATION**

- Use at project boundaries in which final grading is sloped towards pavement or roadways to retain sediment.
- Only applicable when the site is sloped towards the curb such that runoff overtops the curb
- Particularly useful for residential sites when major earth disturbing activities have ceased and final site stabilization (landscape installation) is pending.

### **INSTALLATION/USE PROCEDURE**

- Excavate soil behind curb to a depth of 3-4 inches
- Extend the excavation 3-4 feet behind the curb to form a sediment trap
- Should not be installed on a slope that exceeds 5% as it may be ineffective and compromise the integrity of the curb
- Not suitable if underlying soil is expansive or collapsible, refer to the soils report.
- The sedimentation trap may be implemented behind a sidewalk instead of the curb
- The depth and width of the excavation may be increased if more sediment storage is necessary

### **OPERATOR BMP MODIFICATION OR REPLACEMENT**

- Operator is invited to propose an alternative BMP or modify this preferred BMP. The proposed BMP must match or exceed performance requirements as this preferred BMP. Any deviations from this preferred BMP must be reviewed and accepted by the oversight authority.



- Submit BMP modifications or replacements to the oversight authority for review; including but not limited to; Proprietary system literature, modified illustrations, any operation procedures and maintenance adjustments, etc.

## **MAINTENANCE/MANAGEMENT**

- Inspect at least once every seven calendar days, or once every 14 calendar days and within 24 hours of the occurrence of a storm event of 0.5 inches or greater.
- Remove accumulated sediment when it reaches ½ height of original excavation.

## **PERFORMANCE**

- Sediment, or sediment laden water overtopping the curb, leaving the site, and entering the roadway constitutes BMP failure and must be corrected immediately.

## **REFERENCE**

- CGP 2.2.3
- CPP 2.1.2

## BMP 4- Concrete Washout Pan

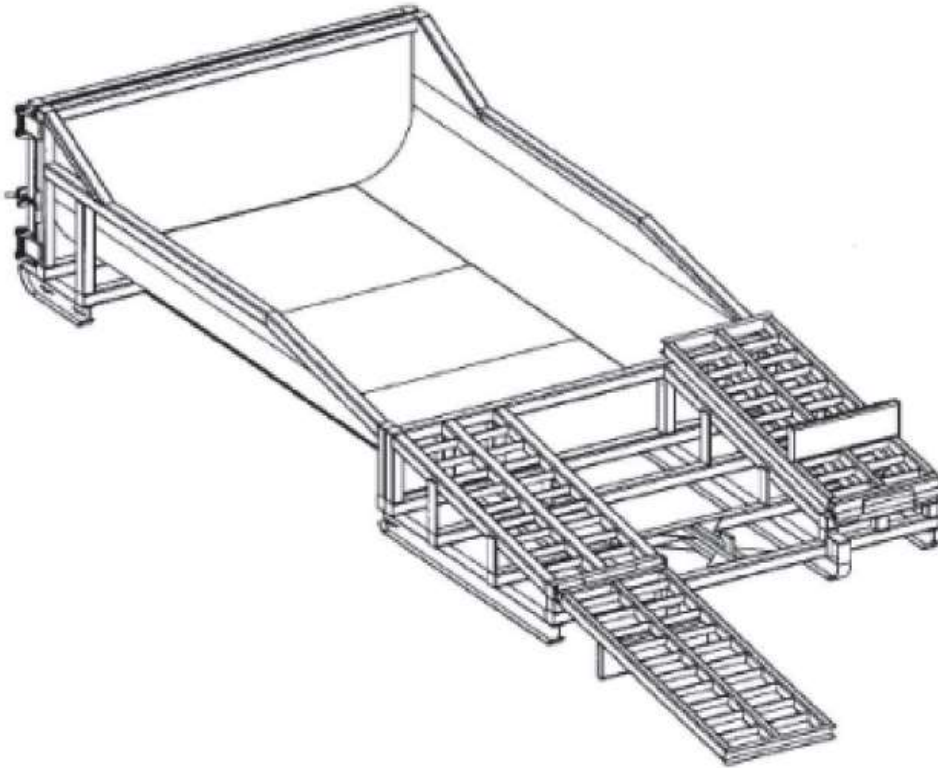

NOT TO SCALE \*

\*Picture for concept only, attach detail for chosen site specific wash out pan

### **APPLICATION**

Concrete waste management is necessary on construction sites when:

- Concrete, grout, or mortar is used as a construction material.
- Concrete truck drums, chutes, and hoses, or other concrete equipment (e.g. hand tools, screeds, shovels, rakes, floats, trowels, and wheelbarrows) are washed on-site and it is not possible to dispose of all concrete wastewater and washout off-site (ready mix plant, etc.).
- Grout or mortar mixing stations are used.

### **INSTALLATION/USE PROCEDURES**

- Locate pans next to track-out or parking pad or provide its own anti-track-out system and area for driver chassis washing. Attach illustration with dimensions. Reference other track-out BMPs as needed to manage site conditions.
- Install a sign at each washout location and identify on the SWPPP BMP map.

- Locate washout facilities a minimum of 50 feet from sensitive areas such as storm drains, open ditches, water bodies, wetlands, or where an infiltration feature will be installed. Protect downstream inlets.
- When the minimum distance from sensitive areas is not practicable, provide secondary containment and attach containment system specifications to this BMP.
- Empty excess concrete onto the ground near the pour site until only liquid cement remains on tools and equipment.
- Wash cement off of the chute, pump equipment, and tools directly into the washout pan.
- Ensure concrete truck operators and concrete transport/disposal service providers have the necessary support to protect water quality.
- The operator is expected to modify the concrete waste management system, location and capacity when necessary as site conditions and operations warrant.
- The operator shall oversee and enforce concrete waste management procedures.
- Educate employees, concrete suppliers, and subcontractors of these concrete waste management requirements. Discuss the concrete management techniques with concrete suppliers before any deliveries are made.
- Incorporate requirements for concrete waste management into concrete supplier and subcontractor agreements.

#### **OPERATOR BMP MODIFICATION OR REPLACEMENT**

- Operator is invited to propose an alternative BMP or modify this preferred BMP. The proposed BMP must match or exceed performance requirements as this preferred BMP. Any deviations from this preferred BMP must be reviewed and accepted by the oversight authority.
- Submit BMP modifications or replacements to the oversight authority for review; including but not limited to; Proprietary system literature, modified illustrations, any operation procedures and maintenance adjustments, etc.

#### **MAINTENANCE/MANAGEMENT**

- Washouts must be maintained to provide adequate holding capacity with one foot of freeboard.
- Washout pan must be cleaned, or additional pans provided and ready for use once the concrete washout pan is 70% full.
- Maintenance includes removal and disposal of hardened concrete and excess liquid or slurry. Excess liquid and slurry shall be pumped or evaporated prior to removal of solids.
  - Attach method of liquid disposal including licensed dumping location.
- Dispose of all materials in conformance with applicable federal, state, and local regulations.
  - Do not discharge liquid or slurry to waterways, storm drains or directly onto ground.

- Inspect washout pans at least weekly, and before and after each concrete operation. During extended wet weather conditions, ensure track out is not occurring.
  - Check overall condition and performance.
  - Check remaining capacity (% full)
  - If using prefabricated pan containers, check for leaks.
- Damaged or leaking washout facilities shall be addressed immediately.

### **PERFORMANCE**

- Pans must be water-tight with sufficient volume plus 1-foot freeboard to meet concrete washout needs in between maintenance/service intervals. Attach concrete waste volume calculations and identify the number washout pans required.
- The performance expected of a wash out pan is to contain all pollutants associated with washout of concrete, slurry, mortar, and other products with no discharge at any time during operations.

It is considered a concrete waste management failure when any of the following occur:

- There are leaks, overflows, or spills of concrete waste. The discharge of concrete washout waters is classified as a “Prohibited Discharge”
- Track-out associated with the concrete washout BMP operation.

### **REFERENCE**

- CGP 2.3.4
- CPP 2.9.1



## BMP 5- Concrete Washout Ground Fixed Systems

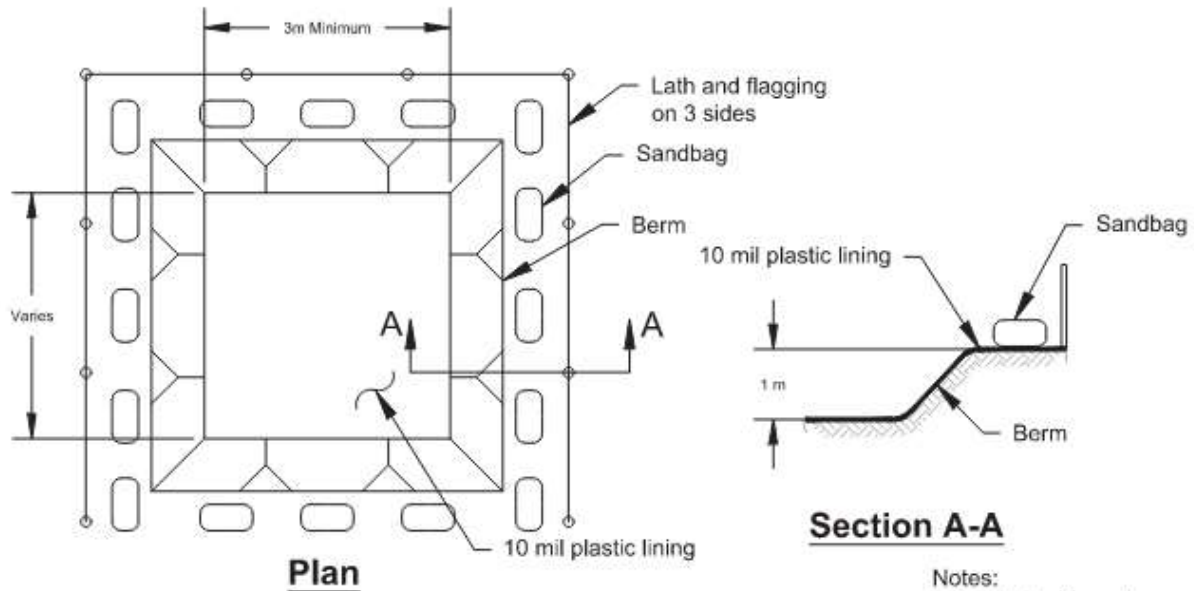

**Type "Below Grade"**

**Notes:**

1. Actual layout determined in the field.
2. A concrete washout sign shall be installed within 10 m of the temporary concrete washout facility.

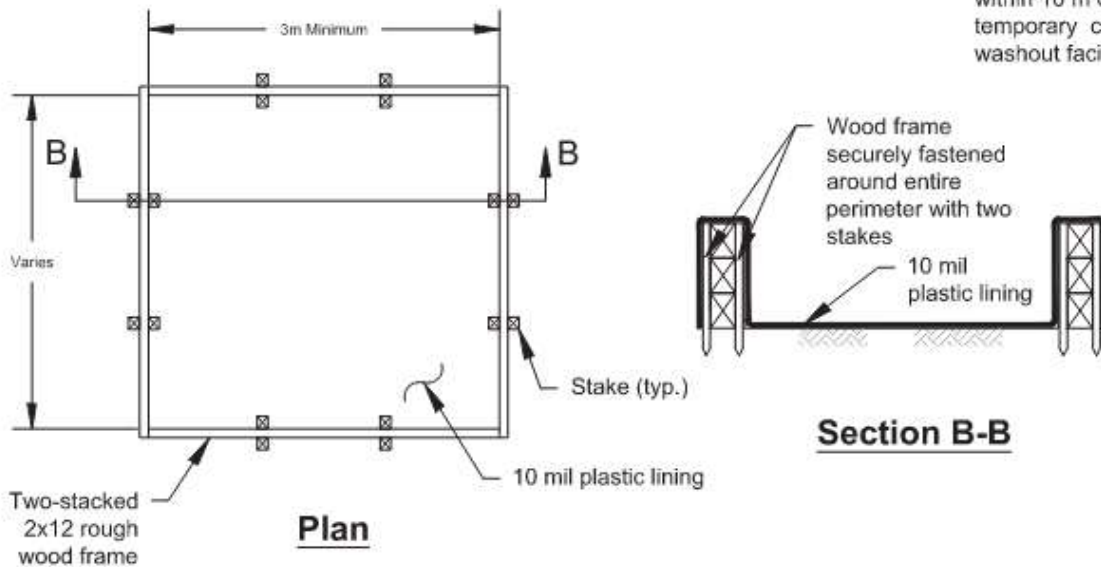

**Type "Above Grade" with Wood Planks**

NOT TO SCALE

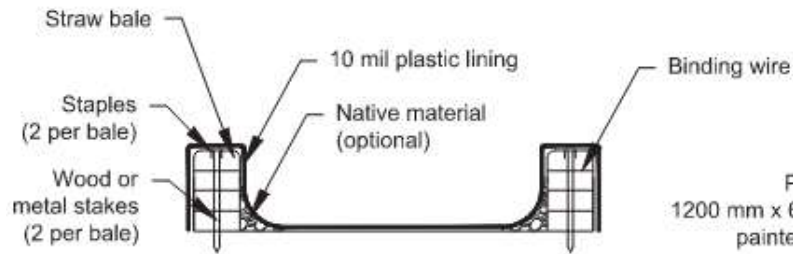

**Section B-B**

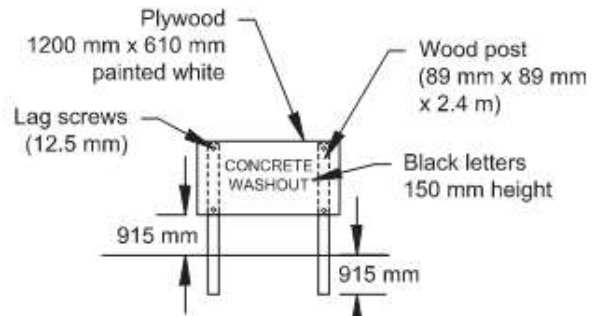

**Concrete Washout Sign Detail (or equivalent)**

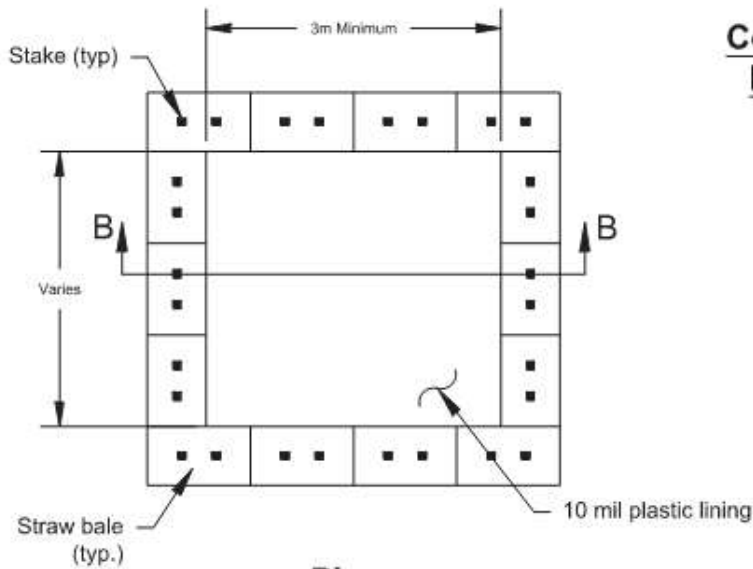

**Plan**

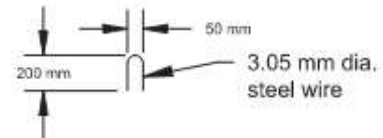

**Staple Detail**

**Notes:**

1. Actual layout determined in the field.
2. The concrete washout sign shall be installed within 10 m of the temporary concrete washout facility.

**Type "Above Grade" with Straw Bales**

NOT TO SCALE

## **APPLICATION**

Concrete waste management is necessary on construction sites when:

- Concrete, grout, or mortar is used as a construction material.
- Concrete truck drums, chutes, and hoses, or other concrete equipment are washed on-site and it is not possible to dispose of all concrete wastewater and washout off-site (ready mix plant, etc.).
- Grout or mortar mixing stations are used.

## **INSTALLATION/USE PROCEDURES**

- The washout facility shall be watertight and impermeable.
- The washout facility may be a self-installed structure or a pre-fabricated structure
- For self-installed washout structures, the lining material shall be a minimum of 10-mil polyethylene sheeting and must be free of holes, tears, or other defects that compromise the impermeability of the material. Liner materials shall be installed in accordance with manufacturer's recommendations.
  - No seams in the plastic are allowed at the bottom of the washout. The soil base shall be prepared free of rocks or other debris that may cause tears or holes in the plastic lining material.
- Washout facilities shall be constructed and maintained with sufficient quantity and volume to contain all liquid and concrete waste generated by washout operations.
- On large sites with extensive concrete work, multiple washouts may be needed to provide adequate capacity.
- Locate pans next to track-out or parking pad or provide its own anti-track-out system and area for driver chassis washing. Attach illustration with dimensions. Reference other track-out BMPs as needed to manage site conditions.
- A sign shall be installed at each washout location.
- Install the washout at the location specified in the SWPPP.
- Locate washout facilities a minimum of 50 feet from sensitive areas such as storm drains, open ditches, water bodies, wetlands, or where an infiltration feature will be installed. Protect downstream inlets.
- When the minimum distance from sensitive areas is not practicable, provide secondary containment and attach containment system specifications to this BMP.
- Keep the washout areas away from other construction traffic and access areas to reduce the likelihood of accidental damage, spills, or tracking.
- Inspect and verify that concrete washout areas are in place prior to the commencement of concrete work.

## **OPERATOR BMP MODIFICATION OR REPLACEMENT**

- Operator is invited to propose an alternative BMP or modify this preferred BMP. The proposed BMP must match or exceed performance requirements as this preferred BMP. Any deviations from this preferred BMP must be reviewed and accepted by the oversight authority.

- Submit BMP modifications or replacements to the oversight authority for review; including but not limited to; Proprietary system literature, modified illustrations, any operation procedures and maintenance adjustments, etc.

### **MAINTENANCE/MANAGEMENT**

- When materials are removed from ground fixed concrete washout systems, build a new structure; or, if the previous structure is still intact, inspect for signs of weakening or damage, and make any necessary repairs. Re-line the structure with new 10-mil polyethylene sheeting after each cleaning.
- Washouts must be maintained to provide adequate holding capacity with one foot of freeboard.
- Once the concrete washout system is 70% full, it is time to remove the existing waste material to allow further use or provide an additional washout facility.
- Maintenance includes removal and disposal of hardened concrete and excess liquid or slurry. Excess liquid and slurry shall be pumped or evaporated prior to removal of solids.
  - Attach method of liquid disposal including licensed dumping location.
- Dispose of all materials in conformance with applicable federal, state, and local regulations.
  - Do not discharge liquid or slurry to waterways, storm drains or directly onto ground.
- Inspect ground fixed concrete washout systems at least weekly, and before and after each concrete operation. During extended wet weather conditions, ensure track out is not occurring.
  - Check overall condition and performance.
  - Check remaining capacity (% full)
  - Check for leaks
- Damaged or leaking washout facilities shall be addressed immediately.
- When concrete washout areas are no longer required for the work, the hardened concrete and containment system shall be removed and disposed of at a licensed waste facility. Attach information of disposal facility. Where concrete is recycled attach recycling facility information.
- Holes, depressions, or other ground disturbances caused by the removal of concrete washout areas shall be backfilled, repaired, and stabilized to prevent erosion.

### **PERFORMANCE**

- The performance expected of a wash out pan is to contain all pollutants associated with washout of concrete, slurry, mortar, and other products with no discharge at any time during operations.

It is considered a concrete waste management failure when any of the following occur:

- There are rips, tears, or defects in the containment system
- Seepage overflows are observed or waste is outside of the containment system
- Track-out associated with the concrete washout BMP operation.

## **REFERENCE**

- CGP 2.3.4,
- CPP 2.4.5, 2.9.1

## BMP 6- Small Concrete Management Operations

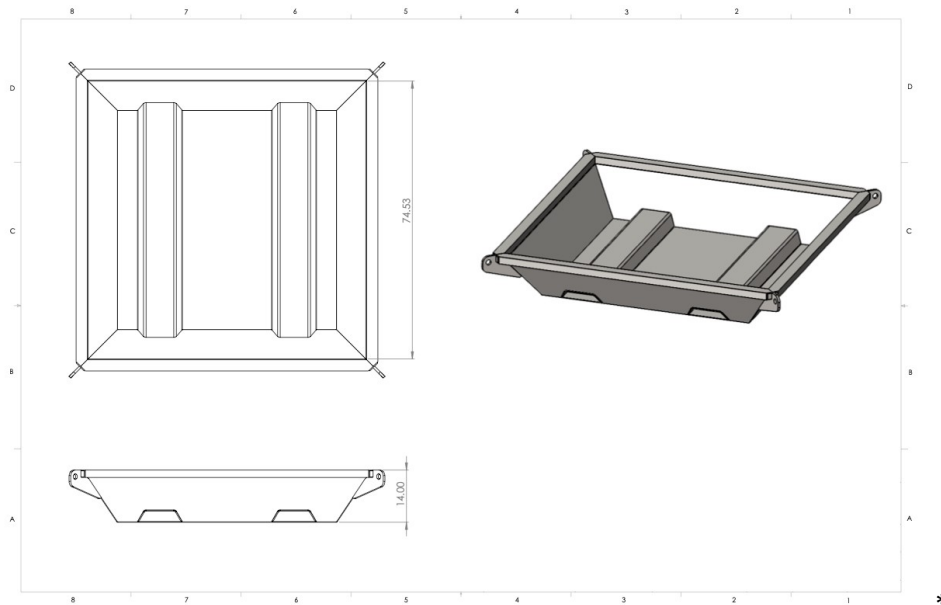

\*Picture for concept purpose only

### **APPLICATION**

- Use for small pours only. Usually for single lot residential homes or other minor projects where the washout volume is small and using a standard proprietary concrete washout pan system is not feasible.

### **INSTALLATION/USE PROCEDURES**

- Small metal pan, plastic pools or equal portable watertight disposable container that can contain caustic materials. Attach dimensions of containers.
- Calculate concrete waste volume required. Attach calculations and identify the number of containment systems needed. Simply repeat this BMP for each day's concrete operation. Provide one additional container for redundancy.
- Maximize the capacity of the small containment system:
  - Empty excess concrete onto the ground near the pour site.
  - Wash cement off of the chute, pump equipment, and tools directly into the washout container.
- Place containers on a flat surface, near the track-out where there is enough room to wash the chassis and remove mud from the tires. Locate on the site BMP map.
- Containers are not allowed in roadway right of ways.
- Do not haul containers away until the waste concrete is set and all water has evaporated.
- Ensure the workforce is informed how to use your concrete management BMP.



## **OPERATOR BMP MODIFICATION OR REPLACEMENT**

- Operator is invited to propose an alternative BMP or modify this preferred BMP. The proposed BMP must match or exceed performance requirements as this preferred BMP. Any deviations from this preferred BMP must be reviewed and accepted by the oversight authority.
- Submit BMP modifications or replacements to the oversight authority for review; including but not limited to; Proprietary system literature, modified illustrations, any operation procedures and maintenance adjustments, etc.

## **MAINTENANCE/MANAGEMENT**

- Cover the containment system when not in use if a rain event is anticipated.
- Individual containers should no longer be used for washout once the volume capacity has reached 70% full. Utilize an additional container.
- This is a one-time disposable BMP, typical maintenance is not necessary. Any exposed concrete washing and disposal operations are considered a BMP failure because the operation was not adequately anticipated and implemented.
- When the daily concrete management operation is completed simply repeat this BMP.

## **PERFORMANCE**

It is considered a concrete waste management failure when any of the following occur:

- Washout container overflows.
- Containers are hauled away prior to concrete set up and when liquid was not completely evaporated.
- When track-out results from washout container inadequate placement.
- When supply truck chassis are being washed outside of the containment system.

## **REFERENCE:**

- CGP 2.3.4
- CPP 2.4.5, 2.9.

## BMP 7- Pavement Saw Cutting-Wet

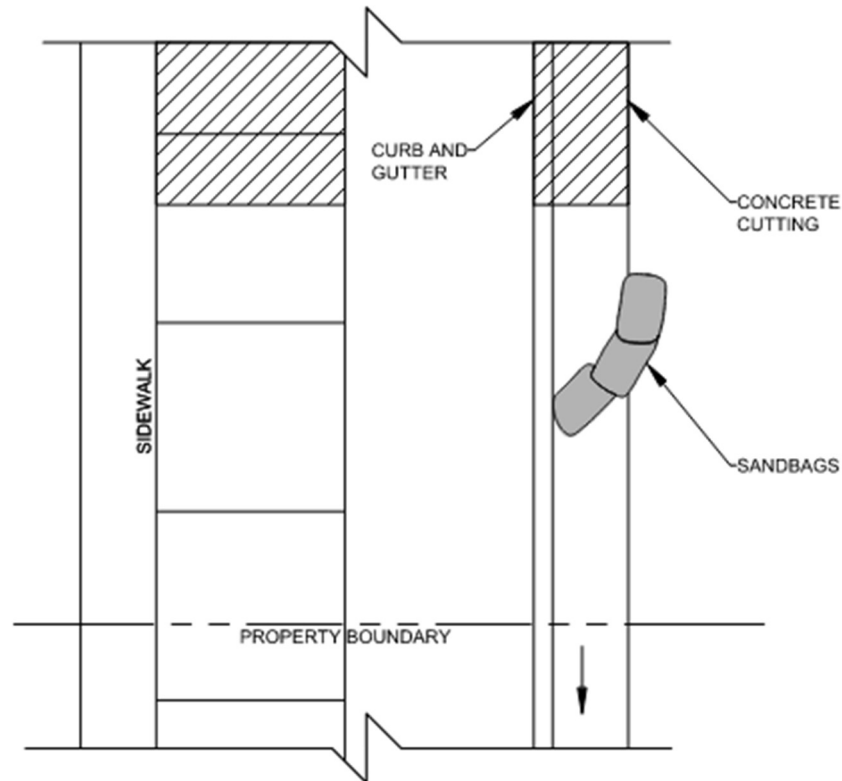

### **APPLICATION**

- Use Pavement Saw Cutting-Wet BMP when cutting pavement with wet saw, especially in curb and gutter applications.
- Appropriate for use when dry cutting is not allowed or dust control is desired.

### **INSTALLATION/USE PROCEDURES**

- Install 6" min diameter sand or gravel bags in a manner to contain slurry from moving downslope from the cutting operation. Double up bags as necessary.
- Install enough bags anticipating the volume of cut slurry.
- Schedule cutting during dry weather periods.
- Remove slurry at the end of day or prior to rain events whichever comes first. When wet conditions exist, mix slurry with dirt or other absorbing material and remove immediately.
  - Dump waste in concrete washout containment system.
  - Dry the waste in a contained area and dispose of waste in regular waste management container.
- Sweep until no more waste can be picked up with a square nose shovel.
- Do not use water to rinse slurry from the cutting operation area, dry clean-up methods only as described above.



### **OPERATOR BMP MODIFICATION OR REPLACEMENT**

- Operator is invited to propose an alternative BMP or modify this preferred BMP. The proposed BMP must match or exceed performance requirements as this preferred BMP. Any deviations from this preferred BMP must be reviewed and accepted by the oversight authority.
- Submit BMP modifications or replacements to the oversight authority for review; including but not limited to; Proprietary system literature, modified illustrations, any operation procedures and maintenance adjustments, etc.

### **MAINTENANCE/MANAGEMENT**

- BMP is installed and removed with each cutting operation, no maintenance is necessary.

### **PERFORMANCE**

- Utilizing water during saw cutting is a great way to capture dust from cutting operations so that dust does not travel out of the cutting operation area nor pollute the air.
- Additionally, utilization of this BMP will prevent high density opacity for nearby drivers and operators.
- Performance criteria to judge application success would be that airborne dust does not occur and slurry is contained and disposed per BMP.

It is considered a BMP failure when any of the following occur:

- The dam created with sand or gravel bags overflows
- Cutting operations are not cleaned up by the end of day or prior to wet conditions.
- Any waste material is not disposed per BMP or otherwise can contaminate water resources

### **REFERENCE:**

- CGP 2.3.4
- CPP 2.9.1

## **BMP 8- Pavement Saw Cutting-Dry**

### **APPLICATION**

- Use for pavement cutting on directly connected pavements or where cutting dust can be washed to drainage systems, especially in curb and gutter applications.

### **INSTALLATION/USE PROCEDURES**

- Schedule cutting during dry weather periods.
- Remove cutting dust immediately following the cutting operation.
- Sweep until no more waste can be picked up with a square nose shovel.
- Dispose of cutting dust in a concrete waste container or regular waste management container.

### **OPERATOR BMP MODIFICATION OR REPLACEMENT**

- Operator is invited to propose an alternative BMP or modify this preferred BMP. The proposed BMP must match or exceed performance requirements as this preferred BMP. Any deviations from this preferred BMP must be reviewed and accepted by the oversight authority.
- Submit BMP modifications or replacements to the oversight authority for review; including but not limited to; Proprietary system literature, modified illustrations, any operation procedures and maintenance adjustments, etc.

### **MAINTENANCE/MANAGEMENT**

- BMP is installed and removed with each cutting operation, no maintenance is necessary.

### **PERFORMANCE**

- BMP application success would be that dust is contained to the cutting operation area and disposed per BMP.

It is considered a BMP failure when any of the following occur:

- Cutting dust enters drainage systems
- Cutting operations are not cleaned up immediately following the cutting operation
- Any waste material is not disposed per BMP or otherwise can contaminate water resources

### **REFERENCE:**

- CGP 2.3.4
- CPP 2.9.1

## BMP 9- Area Drain Filtration

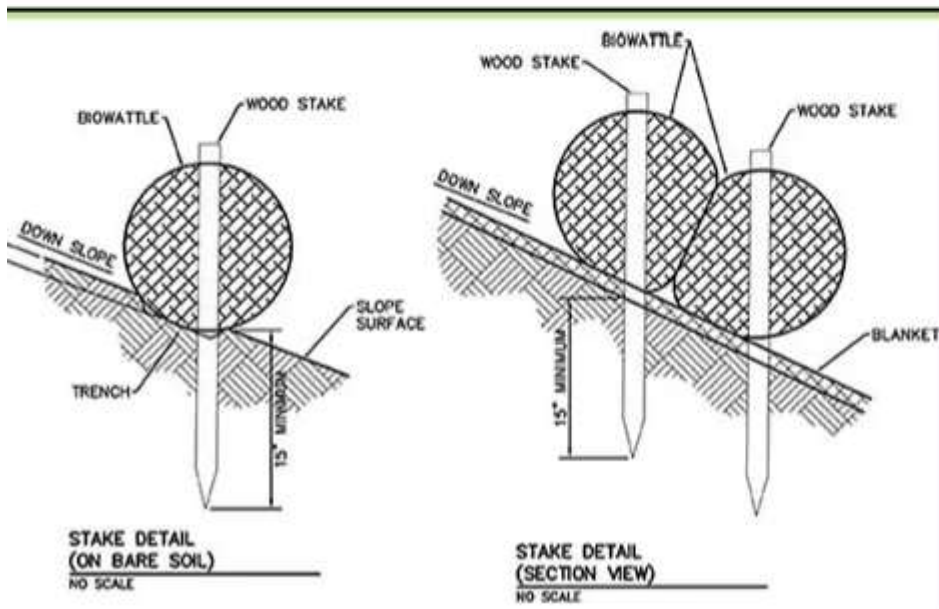
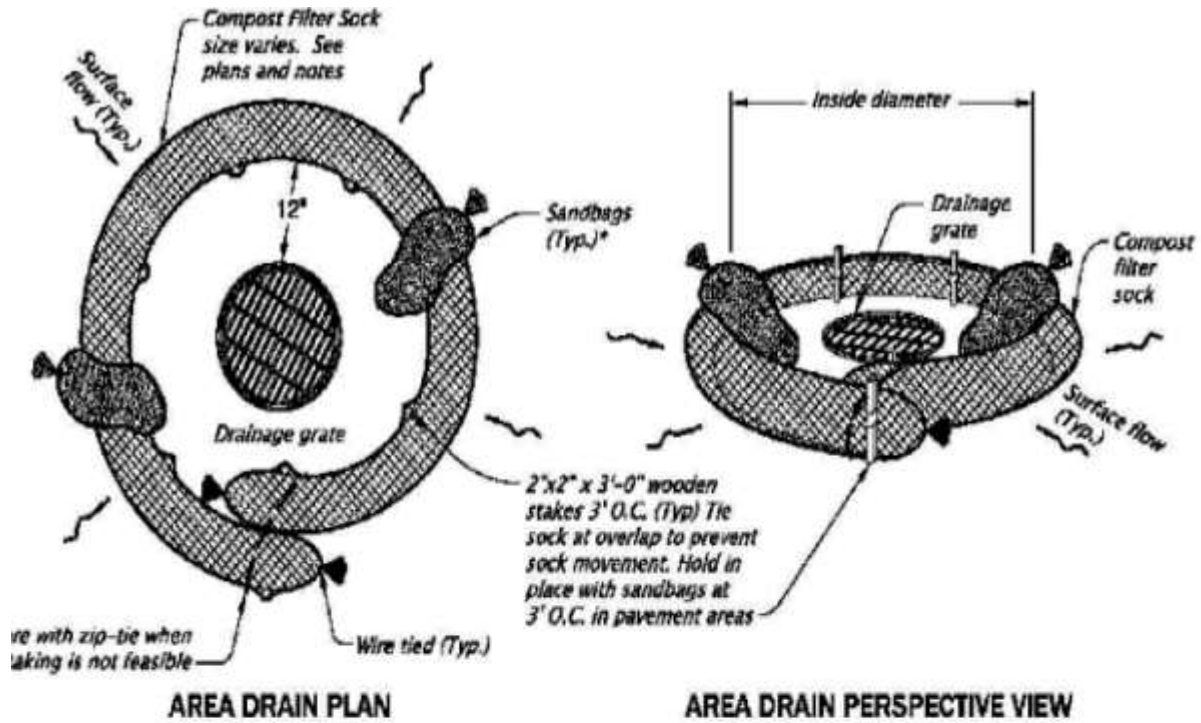

## **APPLICATION**

- Straw wattles or filter tubs are an open weave, mesh tube that is filled with a filter material (compost, wood chips, straw, coir, aspen fiber, or a mixture of materials) used to divert or filter stormwater.
- Straw wattles are a temporary BMP that can be used in the rough grading process of construction. Straw wattles and large filter sock can be used with or without storm drain inlet tops, but not ready for grading of roadway.
- Can be used for area drains until final stabilization is complete.

## **INSTALLATION/USE PROCEDURES**

- On natural ground tubes shall be staked with 2 inches by 2-inch wooden stakes at a maximum spacing of 4 feet. Rebar or similar metal stakes may be used instead of wooden stakes. Filter tubes shall be embedded a minimum of two inches when placed on soil.
- Sand or rock bags shall be placed at a minimum, one foot from each end of the tube and at the middle of the tube.
- The end of tubes shall overlap a minimum of 18 inches when multiple tubes are connected to form a linear control along a contour or a perimeter.
- Straw wattles should wrap around the entirety of the storm drain to prevent sediment and other pollutants from entering the storm drain.
- Follow manufacturer's recommendations for staking or other methods of approved securement when used on pavement.

## **OPERATOR BMP MODIFICATION OR REPLACEMENT**

- Operator is invited to propose an alternative BMP or modify this preferred BMP. The proposed BMP must match or exceed performance requirements as this preferred BMP. Any deviations from this preferred BMP must be reviewed and accepted by the oversight authority.
- Submit BMP modifications or replacements to the oversight authority for review; including but not limited to; Proprietary system literature, modified illustrations, any operation procedures and maintenance adjustments, etc.

## **MAINTENANCE/MANAGEMENT**

- Check straw wattles material to make sure it has not become clogged with sediment or debris. Clogged filter tubes usually lead to standing water behind the filter tube after a rain event. Sediment shall be removed from behind the filter tube before it reaches half the height of the exposed portion of the tube.
- The straw wattles should be checked to ensure it is in continuous contact with the soil at the bottom of the embedment trench. Closely check for rill erosion that may develop under the filter tubes. Eroded spots must be repaired and monitored to prevent reoccurrence. If erosion under the tube continues, additional controls are needed.
- Any straw wattles destroyed by construction operations or UV degradation will need to be removed and replaced.

## **PERFORMANCE**

It is considered a BMP failure when any of the following occur:

- Damaged or not installed to the BMPs details or attached manufacturer illustrations
- Sediment depth around wattle exceeds maintenance tolerances.
- Opening or gaps in straw wattles.

## **REFERENCE**

- CGP 2.2.10

## BMP 10- Rock Check Dam for Channels

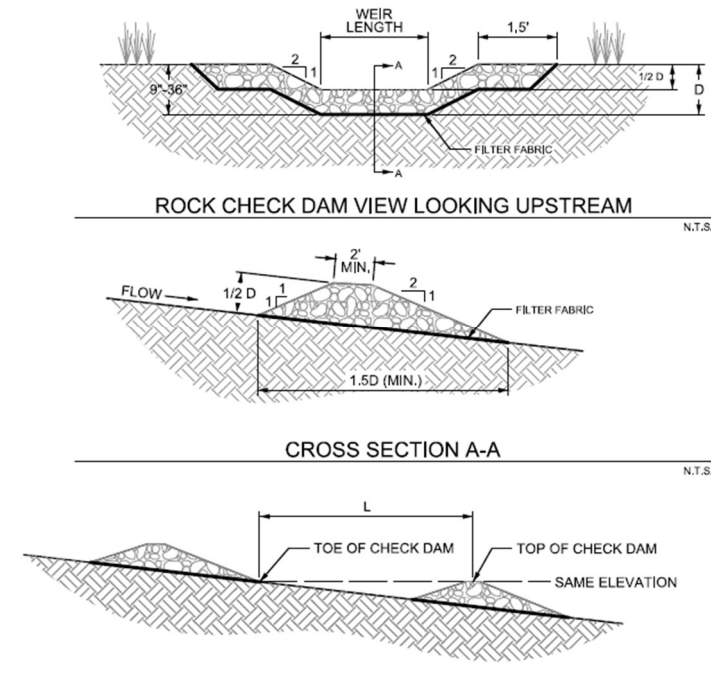

### **APPLICATION**

- Check dams are used in swales and drainage ditches (including those along linear projects such as roadways).
- They can also be used in short swales down a steep slope to reduce velocities.
- Check dams shall not be used in live stream channels.
- Check dams should be installed before the contributing drainage area is disturbed, so as to mitigate the effects on the swale from the increase in runoff.
- If the swale itself is graded as part of the construction activities, check dams are installed immediately upon completion of grading to control velocities in the swale until stabilization is completed.

### **INSTALLATION/USE PROCEDURES**

- Install rock check dam per illustrated detail.  $D=24''$  or less and install the center of the dam about 6" lower than the sides.
- Check dams should be used in conjunction with other sediment reduction techniques prior to releasing flow offsite.
- Use 4" or greater rock diameter and non-woven geotextile fabric under check dams of 12 inches in height or greater. When high flow rates and velocities are anticipated engineering is required.
- Dam height should be between 9 and 36 inches and less than one-third the depth of the channel

- Dams should be spaced such that the top of the downstream dam is at the same elevation as the toe of the upstream dam. On channel grades flatter than 0.4 percent, check dams should be placed at a distance that allows pools to form between each check dam.
- The top of the side of the check dam shall be a minimum of 12 inches higher than the middle of the dam. In addition, the side of the dams shall be embedded a minimum of 18 inches into the side of the drainage ditch, swale or channel to minimize the potential for flows to erode around the side of the dam.
- Use geotextile fabric (of appropriate tensile strength, puncture rating and apparent opening size) under check dams of 12 inches in height or greater.
- Loose soil, wood chips, compost, and other floatable materials that are transportable during runoff should not be used to construct a check dam.

### **ALTERNATIVE DESIGN**

- **Rock Check Dams:**
  - Stone shall be well graded with stone size ranging from 3 to 6 inches in diameter for a check dam height of 24 inches or less. The stone size range for check dams greater than 24 inches is 4 to 8 inches in diameter.
- **Rock Bag Check Dams:**
  - Rock bag check dams should have a minimum top width of 16 inches.
  - Minimum rock bag dam height of 12 inches would consist of one row of bags stacked on top of two rows of bag. The dam shall always be one more row wide than it is high, stacked pyramid fashion.
  - Bags should be filled with pea gravel, filter stone, or aggregate that is clean and free of deleterious material.
  - Sand bags shall not be used for check dams, due to their propensity to break and release sand that is transported by the concentrated flow in the drainage swale or ditch.
  - Bag material shall be polypropylene, polyethylene, polyamide or cotton burlap woven fabric, minimum unit weight 4-ounces-per-square-yard, Mullen burst strength exceeding 300-psi as determined by ASTM D3786, Standard Test Method for Hydraulic Bursting Strength of Textile Fabrics-Diaphragm Bursting Strength Tester Method, and ultraviolet stability exceeding 70 percent.
  - PVC pipes may be installed through the dam to allow for controlled flow through the dam. Pipe should be schedule 40 or heavier polyvinyl chloride (PVC) having a nominal internal diameter of 2 inches.
- **Sack Gabion Check Dams:**
  - Sack gabion check dams may be used in channels with a contributing drainage area of 5 acres or less.
  - Sack gabions shall be wrapped in galvanized steel, woven wire mesh. The wire shall be 20 gauge with 1-inch diameter, hexagonal openings.
  - Wire mesh shall be one piece, wrapped around the rock, and secured to itself on the downstream side using wire ties or hog rings.

- o Sack gabions shall be staked with  $\frac{3}{4}$  inch rebar at a maximum spacing of three feet. Each wire sack shall have a minimum of two stakes.
- o Stone shall be well graded with a minimum size range from 3 to 6 inches in diameter.
- **Organic Filter Tube Check Dams:**
  - o Organic filter tubes may be used as check dams in channels with a contributing drainage area of 5 acres or less.
  - o Organic filter tubes shall be a minimum of 12 inches in diameter.
  - o Filter material used within tubes to construct check dams shall be limited to coir, straw, aspen fiber and other organic material with high cellulose content. The material should be slow to decay or leach nutrients in standing water.
  - o Staking of filter tubes shall be at a maximum of 4 foot spacing and shall alternate through the tube and on the downstream face of the tube.

### **OPERATOR BMP MODIFICATION OR REPLACEMENT**

- Operator is invited to propose an alternative BMP or modify this preferred BMP. The proposed BMP must match or exceed performance requirements as this preferred BMP. Any deviations from this preferred BMP must be reviewed and accepted by the oversight authority.
- Submit BMP modifications or replacements to the oversight authority for review; including but not limited to; Proprietary system literature, modified illustrations, any operation procedures and maintenance adjustments, etc.

### **MAINTENANCE/MANAGEMENT**

- Inspect the check dam system each report period and after storm events.
- Remove silt when sediment accumulation reaches approximately  $\frac{1}{3}$  the height of the dam.
- Inspect for erosion beneath and around the check dam (particularly where the edge of the dam meets the side of the channel) and restore as needed each report period.
- If erosion continues to be a problem, modifications to the check dam or additional controls must be engineered.

### **PERFORMANCE**

- Check dam systems are intended to perform as engineered up to .25" of rain fall
- Rock check dams are performing as intended if the drainage channel they are protecting does not develop deep erosive gulleys between dams and the dam itself is not being undercut by erosion or eroded to either side of the dam.
- Due to the minimal sediment capture capability of check dams, good performance will include accumulations of sediment on the upstream side of dams between maintenance intervals.

It is considered a BMP failure when any of the following occur:

- System not installed per illustrated detail, system not maintained, or system damaged by construction operations.



- Erosion damage resulting in variance from detail dimensions

#### **REFERENCE**

- U-CGP 2.2.11 – “Minimize erosion of constructed or natural site drainage feature channels and their embankments, outlets, adjacent streambanks, slopes, and downstream waters. Use erosion controls and velocity dissipation devices within and along the length of any constructed or natural site drainage feature channel and at any outlet to slow down runoff and minimize erosion.”

## BMP 11- Straw Wattle Check Dam for Channels

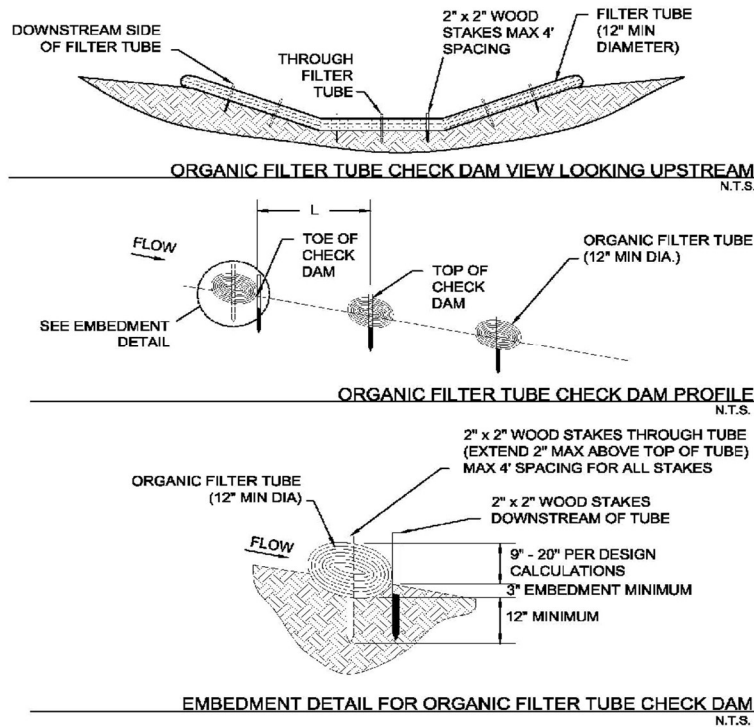

### **APPLICATION**

- Check dams are used in swales and drainage ditches (including those along linear projects such as roadways).
- They can also be used in short swales down a steep slope to reduce velocities.
- Check dams shall not be used in live stream channels.
- Check dams should be installed before the contributing drainage area is disturbed, so as to mitigate the effects on the swale from the increase in runoff.
- If the swale itself is graded as part of the construction activities, check dams are installed immediately upon completion of grading to control velocities in the swale until stabilization is completed.

### **INSTALLATION/USE PROCEDURE**

- Dam height should be between 9 and 36 inches and less than one-third the depth of the channel
- Dams should be spaced such that the top of the downstream dam is at the same elevation as the toe of the upstream dam. On channel grades flatter than 0.4 percent, check dams should be placed at a distance that allows small pools to form between each check dam.
- The top of the side of the check dam shall be a minimum of 12 inches higher than the middle of the dam. In addition, the side of the dams shall be embedded a minimum of 18 inches into the side of the drainage ditch, swale

or channel to minimize the potential for flows to erode around the side of the dam.

- Check dams should be used in conjunction with other sediment reduction techniques prior to releasing flow offsite.
- Use geotextile fabric (of appropriate tensile strength, puncture rating and apparent opening size) under check dams of 12 inches in height or greater.
- Loose soil, wood chips, compost, and other floatable materials that are transportable during runoff should not be used to construct a check dam.

### **ALTERNATIVE DESIGN**

- See “Rock Check Dam for Channels”

### **OPERATOR BMP MODIFICATION OR REPLACEMENT**

- Operator is invited to propose an alternative BMP or modify this preferred BMP. The proposed BMP must match or exceed performance requirements as this preferred BMP. Any deviations from this preferred BMP must be reviewed and accepted by the oversight authority.
- Submit BMP modifications or replacements to the oversight authority for review; including but not limited to; Proprietary system literature, modified illustrations, any operation procedures and maintenance adjustments, etc.

### **MAINTENANCE/MANAGEMENT**

- Inspect the check dam system each report period and after storm events.
- Remove silt when sediment accumulation reaches approximately 1/3 the height of the dam.
- Inspect for erosion beneath and around check dam (particularly where edge of the dam meets the side of the channel) and restore as needed each report period.
- If erosion continues to be a problem, modifications to the check dam or additional controls must be engineered.

### **PERFORMANCE**

- Check dam systems are intended to perform as engineered up to .25” of rain fall
- Check dams are performing as intended if the drainage channel they are protecting does not develop deep erosive gulleys between dams and the dam itself is not being undercut by erosion or eroded to either side of the dam.
- Due to the minimal sediment capture capability of check dams, good performance will include accumulations of sediment on the upstream side of dams between maintenance intervals.

It is considered a BMP failure when any of the following occur:

- System not installed per illustrated detail, system not maintained, or system damaged by construction operations.
- Erosion damage resulting in variance from detail dimensions.

## **REFERENCE**

- U-CGP 2.2.11 – “Minimize erosion of constructed or natural site drainage feature channels and their embankments, outlets, adjacent streambanks, slopes, and downstream waters. Use erosion controls and velocity dissipation devices within and along the length of any constructed or natural site drainage feature channel and at any outlet to slow down runoff and minimize erosion.”

## BMP 12- Culvert Sediment Barrier

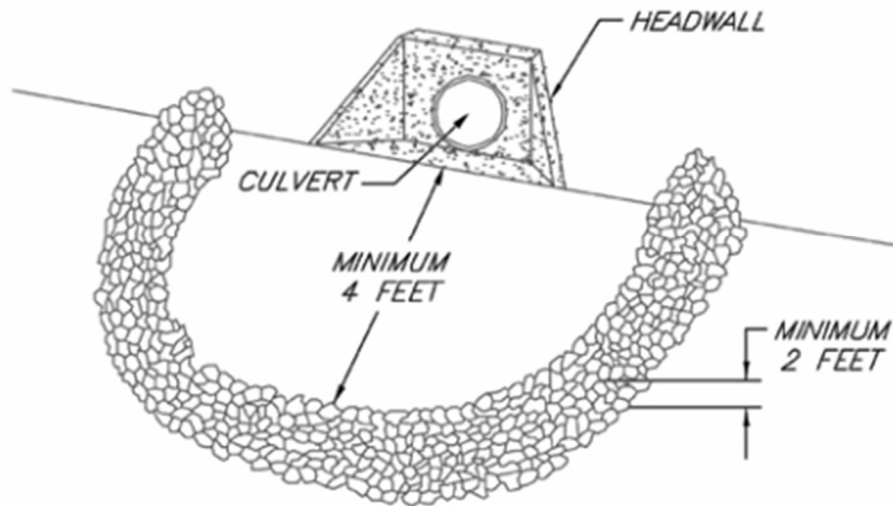

### **APPLICATION**

A culvert inlet sediment barrier is a temporary rock barrier at a culvert inlet. The purpose of the barrier is to reduce the amount of sediment that enters the culvert by creating a small ponding area for the sediment to settle out.

- For use on a site with open culverts within the project area that are exposed to runoff.

### **INSTALLATION/USE PROCEDURES**

- A geotextile should be placed between the stone barrier and the natural ground.
- Surround all sides of the culvert with Class II Channel Lining at a minimum of 4 feet from the culvert.
- The barrier must be designed to ensure that no bypasses occur up to 0.5" of rainfall
- Control the location of the sediment barrier spillway by placing an overflow notch at a selected location in the middle portion of the barrier.
  - The notch should be at least six inches lower than the rest of the barrier.
  - The downgradient portion of the overflow notch should be protected from erosion caused by potential spillover with Class II Channel Lining.
- The upstream face of the barrier should consist of smaller stone to decrease the flow rate through the stone.

- If a culvert inlet sediment barrier is intended to be used for long-term storm water management, design and installation must be approved by an accredited engineer.

### **OPERATOR BMP MODIFICATION OR REPLACEMENT**

- Operator is invited to propose an alternative BMP or modify this preferred BMP. The proposed BMP must match or exceed performance requirements as this preferred BMP. Any deviations from this preferred BMP must be reviewed and accepted by the oversight authority.
- Submit BMP modifications or replacements to the oversight authority for review; including but not limited to; Proprietary system literature, modified illustrations, any operation procedures and maintenance adjustments, etc.

### **MAINTENANCE/MANAGEMENT**

- Inspect the condition of the sediment barrier weekly and after every rainfall event greater than one-half inch. Erosion and scouring would necessitate barrier reinforcement.
- Remove sediment and/or debris when depth reaches one-half the height of the barrier.

### **PERFORMANCE**

- A culvert inlet sediment barrier is expected to utilize sediment deposition to the maximum extent possible before allowing runoff to enter the culvert.
- The overflow spillway should not compromise the capacity of the berm to slow the flow of the first half inch of rain

### **REFERENCE**

- CGP 2.2.11
- CPP 2.3

## BMP 13- Silt Fence

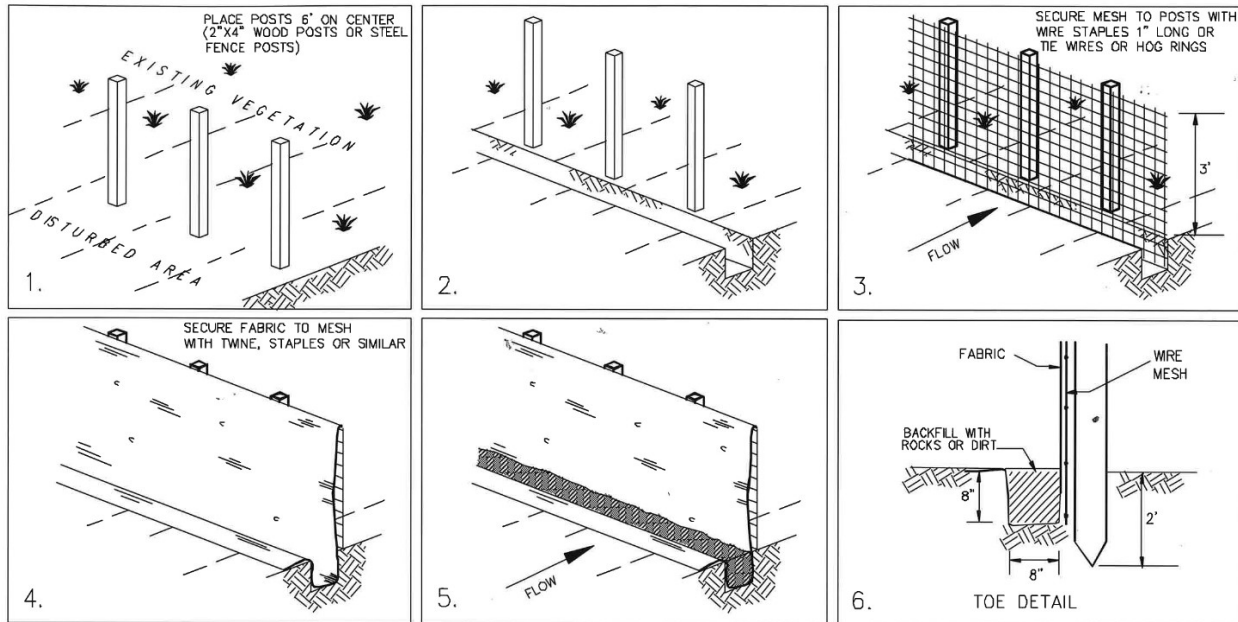

### **APPLICATION**

A silt fence when properly installed and maintained can help mitigate the discharge of sediment in storm water runoff. It can be used in multiple applications such as:

- Downstream project boundaries
- Downstream side(s) of erodible stockpiled materials.
- Minor channels or slopes when calculations show runoff volumes will not exceed the anticipated volume capacity and strength of the system.

A silt fence is not intended for:

- Controlling large volumes of concentrated runoff. Use an alternative BMP
- Border control or limits of construction site only (i.e. not intended to fulfill the same purpose as construction fencing)

### **INSTALLATION/PROCEDURE/CALCULATIONS**

- Install silt fence per detail dimensions, description and materials or -
- For proprietary systems attach all design, performance, installation, maintenance requirements and the proprietary BMP detail documents. All requirements of this BMP remain except for any differences necessary to achieve design performance.
- Install silt fence downstream of all necessary exposed boundaries as shown by the grading sheet, demolition map, phasing map, and or SWPPP BMP map, etc. Attach topographic maps for all construction phases to this BMP or reference where these maps are found in the SWPPP.
- Install silt fence along contours of the slope to maximize effectiveness.
- Overlap each fence segment in a series by at least 6 inches to prevent gaps.

- The end of the silt fence must be installed in a “J-hook” to treat runoff effectively. Flare the ends uphill to provide storage capacity of storm water runoff
- Attach engineering calculations for sites with steep slopes, for large areas clear of vegetation and when runoff rates or when runoff volumes behind fences will feasibly cause failure for storm events less than 2yr 24hr intensities and volumes. In this case, engineering calculations are required or as allowed by oversight authority.
- Ensure all workers are trained on proper installation, maintenance, and inspection of silt fences.

### **OPERATOR BMP MODIFICATION OR REPLACEMENT**

- Operator is invited to propose an alternative BMP or modify this preferred BMP. The proposed BMP must match or exceed performance requirements as this preferred BMP. Any deviations from this preferred BMP must be reviewed and accepted by the oversight authority.
- Submit BMP modifications or replacements to the oversight authority for review; including but not limited to; Proprietary system literature, modified illustrations, any operation procedures and maintenance adjustments, etc.

### **MAINTENANCE/MANAGEMENT**

- Inspect the silt fence prior to a forecasted rain event and during weekly inspections.
- Maintain or repair within the period given by the inspector following city and state code within the reporting period or prior to storm event.
- Inspect silt fence after storm events. Restore any fence damaged back to the installation requirements.
- Remove accumulated sediment when it reaches one-third fence height or as specified by proprietary system.

### **PERFORMANCE**

- A silt fence allows water to pass trapping sediment behind. Runoff going around, under or over silt fence would indicate a silt fence system failure.
- A silt fence is expected to filter sediment for storm events less than 2yr 24hr storm events. Fence failures for events less than a 2yr 24hr storm feasibly means the silt fence was either designed, installed, was unmaintained, was damaged by construction operations or the silt fence was not the best BMP for the site exposure. When the area tributary to the fence results in runoff rates greater than silt fence design capability, provide conveyance swales and retention pond BMPs or as per other CGP options.

### **REFERENCE**

- CGP 2.2.3, 2.2.5, 2.2.11, 2.2.12, 7.3.3



## BMP 14- Earth Berm Barrier

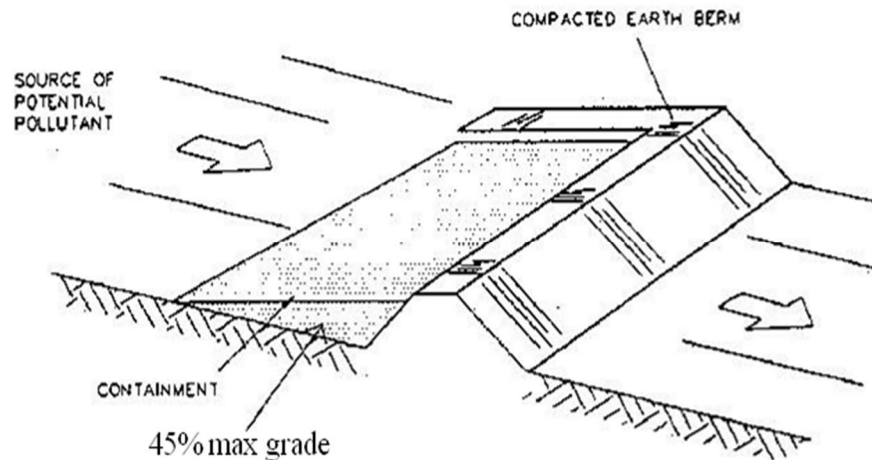

### **APPLICATION**

A temporary containment control constructed of compacted soil.

- Construct around waste and materials storage area.
- Construct around staging and maintenance areas.
- Construct around vehicle parking and servicing areas.

Not intended for erosion control.

### **INSTALLATION/USE PROCEDURES**

- Construct an earthen berm downhill of the area to be controlled. The berm should surround fueling facilities and maintenance areas on three sides to provide containment.
- Berm needs to be a minimum of 1 foot tall by 1 foot wide and be compacted by earth moving equipment.
- The berm should be protected from heavy equipment traffic through signage or training

### **OPERATOR BMP MODIFICATION OR REPLACEMENT**

- Operator is invited to propose an alternative BMP or modify this preferred BMP. The proposed BMP must match or exceed performance requirements as this preferred BMP. Any deviations from this preferred BMP must be reviewed and accepted by the oversight authority.
- Submit BMP modifications or replacements to the oversight authority for review; including but not limited to; Proprietary system literature, modified illustrations, any operation procedures and maintenance adjustments, etc.

### **MAINTENANCE/MANAGEMENT**

- Observe daily for any non-stormwater discharge.
- Look for runoff bypassing ends of berms eroding, or breaching.
- Repair or replace damaged areas of the berm and remove accumulated sediment.

- Recompact soil around the berm as necessary to minimize erosion rates.

### **PERFORMANCE**

- An earthen berm should be able to contain incidental spills in the area that it is installed while the spill control plan in the SWPPP is being put into effect.

### **REFERENCE**

- CGP 2.2.11
- CPP 2.3

## BMP 15- Filter Tubes on Slopes

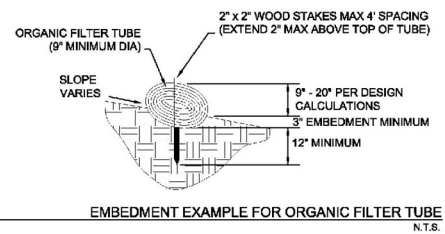
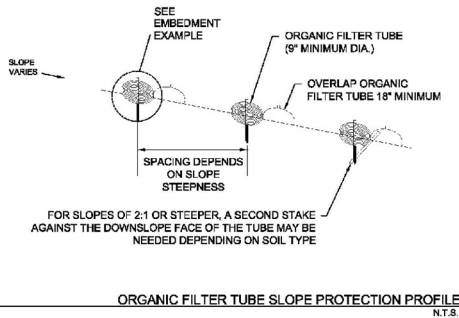
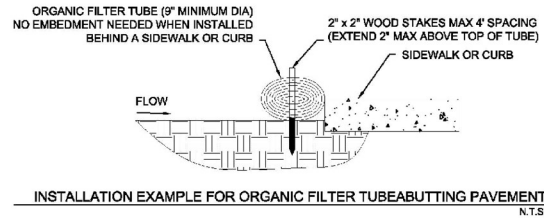
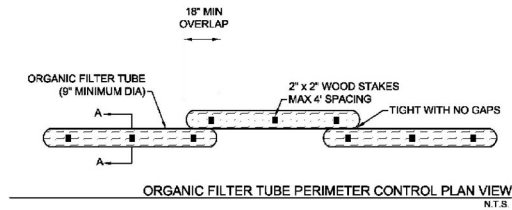

### APPLICATION

Filter tubes are also called fiber rolls, fiber logs, wattles, mulch socks, and/or coir rolls. The tubes can be filled with organic material (compost, wood chips, straw, coir, aspen fiber, or a mixture of materials) or geosynthetic material. Though filter tubes have many uses, this BMP focuses on slope management.

- If the tubes will be left onsite as part of the final stabilization plan (such as in Arid and Semi-Arid areas with exceptions to final stabilization timeline requirements) they must be constructed of 100 percent biodegradable jute, coir, sisal or similar natural fiber or 100 percent UV photodegradable plastic, polyester or geosynthetic material.
- Filter tubes can be used to treat sheet flow over a short distance and can be used on steep slopes as both sediment and erosion control.
- Filter tubes work by detaining flow and capturing sediment as a linear control along the contours of a slope, or as a perimeter control down-slope of a disturbed area (when appropriately sized).
- Filter tubes are most effective with coarse to silty soil types; additional controls may be needed to remove fine silts and clays suspended in stormwater.

### INSTALLATION/USE PROCEDURES

- Filter tubes should be installed along the contour.
- Tubes shall be staked with 2-inch by 2-inch wooden stakes at a maximum spacing of 4 feet. Rebar or similar metal stakes may be used instead of wooden stakes.
- When placed on pavement, sand or rock bags shall be placed abutting the down-slope side of the tubes to prevent runoff from dislodging the tubes. At a

minimum, bags shall be placed one foot from each end of the tube and at the middle of the tube.

- Filter tubes shall be embedded a minimum of three inches when placed on soil. Placement on rock shall be designed as placement on pavement.
- The end of tubes shall overlap a minimum of 18 inches when multiple tubes are connected to form a linear control along a contour or a perimeter.
- Loose mulch material shall be placed against the log on the upstream side to facilitate contact with the ground.
- The last 10 feet (or more) at the ends of a line of tubes shall be turned upslope to prevent bypass by stormwater. Additional turned-upslope lengths of tubes may be needed every 200 to 400 linear feet, depending on the traverse slope along the line of tubes.
- The most common sizes of tubes are 6 to 24 inches in diameter; however, tubes are available in sizes as small as 4 inches and up to 36 inches in diameter. The designer shall specify a diameter based on the site application. Tubes less than 8 inches in diameter when filled will require more frequent maintenance if used.
- When using manufactured tubes, the manufacturer's recommendations for diameter and spacing based on slope, flow velocities, and other site conditions shall be followed and documented in a site's SWPPP.

#### **OPERATOR BMP MODIFICATION OR REPLACEMENT**

- Operator is invited to propose an alternative BMP or modify this preferred BMP. The proposed BMP must match or exceed performance requirements as this preferred BMP. Any deviations from this preferred BMP must be reviewed and accepted by the oversight authority.
- Submit BMP modifications or replacements to the oversight authority for review; including but not limited to; Proprietary system literature, modified illustrations, any operation procedures and maintenance adjustments, etc.

#### **MAINTENANCE/MANAGEMENT**

- Organic filter tubes should be inspected regularly each inspection period.
- The filter tube should be checked to ensure that it is in continuous contact with the soil at the bottom of the embedment trench. Closely check for rill erosion that may develop under the filter tubes. Eroded spots must be repaired and monitored to prevent reoccurrence. If erosion under the tube continues, additional controls are needed.
- Staking shall be checked to ensure that the filter tubes are not moving due to stormwater runoff. Repair and re-stake slumping filter tubes. Tubes that are split, torn or unraveling shall be repaired or replaced.
- Check the filter tube material to make sure that it has not become clogged with sediment or debris. Clogged filter tubes usually lead to standing water behind the filter tube after the rain event. Sediment shall be removed from behind the filter tube before it reaches half the height of the exposed portion of the tube.



## **PERFORMANCE**

- Organic filter tubes are performing as intended if sheet flow of runoff is passing over or through the barrier and not simply around it, bypassing the control.
- Additionally, performance is achieved if the filter tube barrier is effectively minimizing the off-site discharge of sediment from the drainage area it is controlling and does not develop erosive rills/gullies between filter tubes and the tubes are not being undercut by erosion or eroded to either side of the barrier.
- Due to the relatively smaller sediment capture capability of these filter tubes, as compared to taller barriers, good performance will include accumulations of sediment on the upstream side of filter tubes until maintenance occurs, which will likely require more frequent maintenance.

## **REFERENCE**

- CGP 2.2.3, 2.2.5, 2.2.11
- CPP 2.3

## BMP 16- Drop Inlet Bag with Overflow

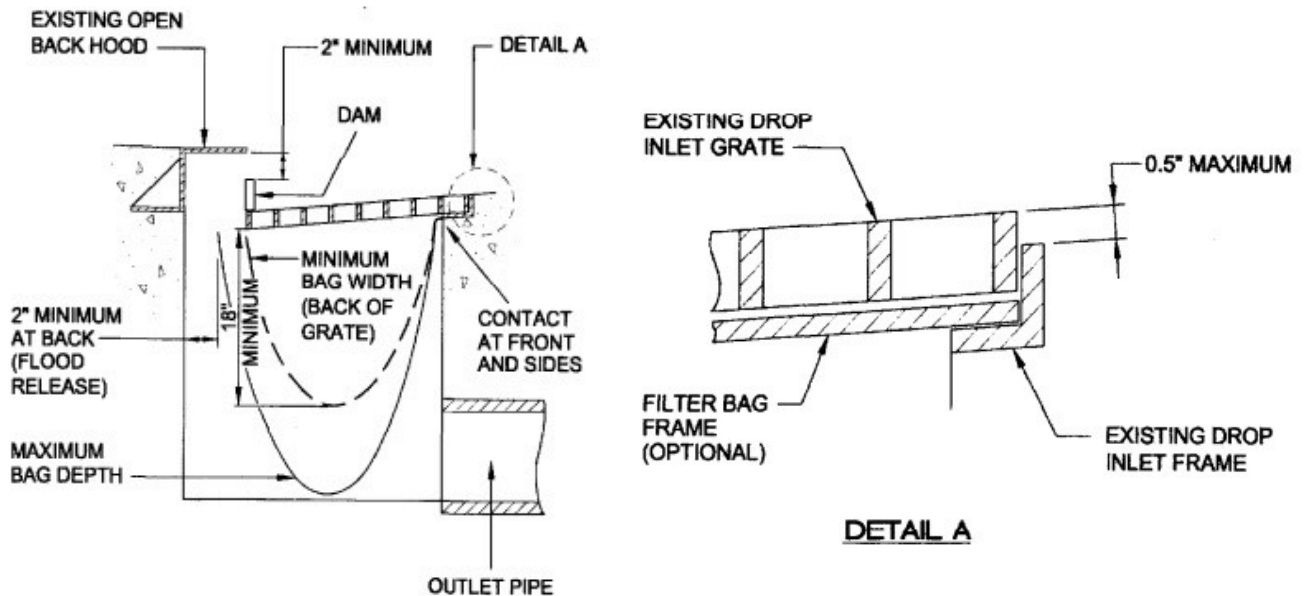

[Picture for concept purpose only]

### **APPLICATION**

- Use drop inlet bag BMPs with overflow systems at roadway sag locations. Note, these BMP can be appropriate on collector roadways when inspections show success at preventing surface ponding. Note, the local municipality will need to evaluate the traffic risk on a case by case basis.
- Use drop inlet bag BMPs when other surface inlet BMPs like sand bags are less feasible due to high traffic in the area.

### **INSTALLATION/USE PROCEDURES**

- Attach drop inlet bag proprietary manufacturer installation and maintenance detail literature to this BMP. Provide drop inlet bag system designed for inlet type needed, e.g. open face, not open face gutter, etc.
- Install the drop inlet bag system in accordance with the manufacturer literature.

### **OPERATOR BMP MODIFICATION OR REPLACEMENT**

- Operator is invited to propose an alternative BMP or modify this preferred BMP. The proposed BMP must match or exceed performance requirements as this preferred BMP. Any deviations from this preferred BMP must be reviewed and accepted by the oversight authority.
- Submit BMP modifications or replacements to the oversight authority for review; including but not limited to; Proprietary system literature, modified illustrations, any operation procedures and maintenance adjustments, etc.

### **MAINTENANCE/MANAGEMENT**

- Inspect and maintain if necessary every report period. Empty and dispose of debris accumulations when the bag capacity has reached 50% full or before the bag becomes unmanageable or ineffective.
- Inspect the unit prior to and after storm events. Large storm events will scour sediment from almost all roadway inlet BMPs, therefore regular maintenance is the best management practice.
- Remove and dispose of any sediment found inside the inlet box resulting from BMP failure or resulting during maintenance operations.
- Conduct any maintenance required by the drop inlet bag manufacturer.
- In collector roadways or other locations oversight authority requires, check during storm events and prevent hazardous driving conditions.

### **PERFORMANCE**

- A drop inlet bag is expected to prevent debris and large sediment particles from entering a storm drain.
- Minor ponding should be expected, but the overflow would prevent excessive ponding
- A drop inlet bag should not allow the accumulated debris to fall into the structure it is protecting at any time both during maintenance and removal. The design and installation specifications should support this ideal.

It is considered a BMP failure when any of the following occur:

- System not installed or maintained to installation and operation requirements
- System not installed and maintained to manufacturer requirements
- Sediment scour resulting from irregular maintenance.
- Sediment left in inlet following maintenance.
- Excessive ponding resulting from irregular maintenance or blocked overflow.

### **REFERENCE**

- Construction General Storm Water Permit (CGP) 2.2.10
- Common Plan Permit (CPP) 2.1.3

## BMP 17- Gravel Bag Curb Inlet Protection

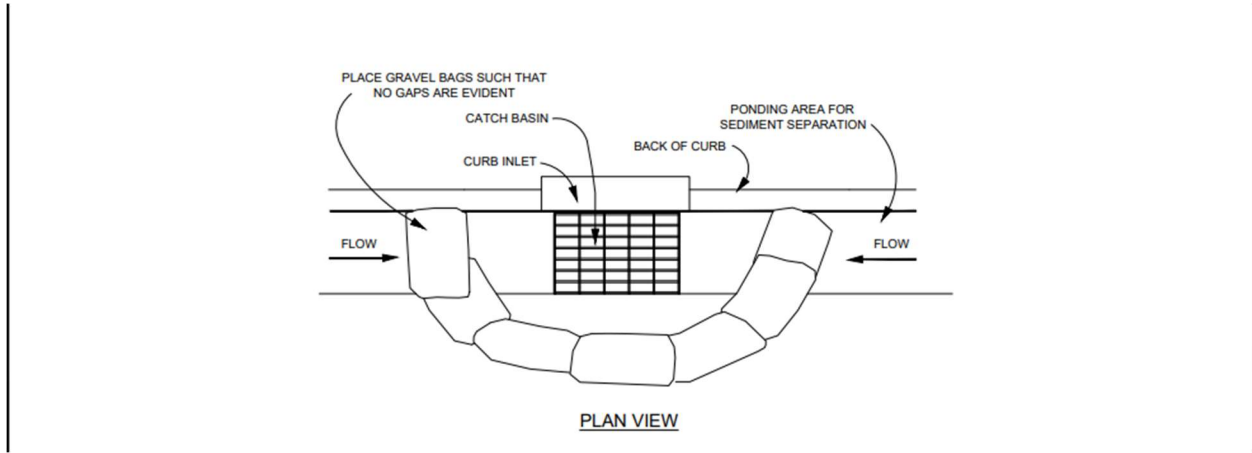

### **APPLICATION**

- The purpose of placing gravel bags around an inlet or other runoff receiving area is to slow the flow of water to allow sediment deposition to be maximized before runoff enters the inlet or other receiving area.
- Ideal for areas near storm drains, curb inlets, and other drainage structures.
- Not intended for high-flow areas without additional support measures.
- Do not use on collector roadways and where the control could create safety concerns such as hydroplaning.
- Not to be used during winter months due to snow removal.

### **INSTALLATION/USE PROCEDURES**

- Ensure the bags are properly positioned to maximize the area available for ponding.
- Use appropriate types of inlet protection based on site-specific conditions.
- Install inlet protection measures that remove sediment from discharges prior to entry into any storm drain inlet that carries storm water flow from your site to surface water of the state, provided you have authority to access the storm drain inlet.
- This BMP is designed for 1/4" (~2yr 10min intensity) rain storm events.
- Train SWPPP inspection and maintenance team

### **OPERATOR BMP MODIFICATION OR REPLACEMENT**

- Operator is invited to propose an alternative BMP or modify this preferred BMP. The proposed BMP must match or exceed performance requirements as this preferred BMP. Any deviations from this preferred BMP must be reviewed and accepted by the oversight authority.
- Submit BMP modifications or replacements to the oversight authority for review; including but not limited to; Proprietary system literature, modified illustrations, any operation procedures and maintenance adjustments, etc.



### **MAINTENANCE/MANAGEMENT**

- Regularly inspect and maintain the system to ensure proper function.
- If repairs are needed, repair the system as soon as practicable.
- Inspect inlet protection before and after storm events or other large volume runoff events.
- Remove accumulated sediment and debris when deposits are  $\frac{1}{3}$  the height of the gravel bag barrier.
- Ensure a clear area around inlet protection devices to facilitate inspections and maintenance.
- Check during storm events and prevent hazardous surface water driving conditions.

### **PERFORMANCE**

- Inlet protection is considered effective if it mitigates target pollutants from entering the stormwater system.
- Inlet protection system resulting in spill over during an event less than 1/4" (~2yr 10min intensity) of rain is considered a failure.

### **REFERENCE**

- CGP-2.2.10
- CPP- 2.1.3

## BMP 18- Gutter Dam

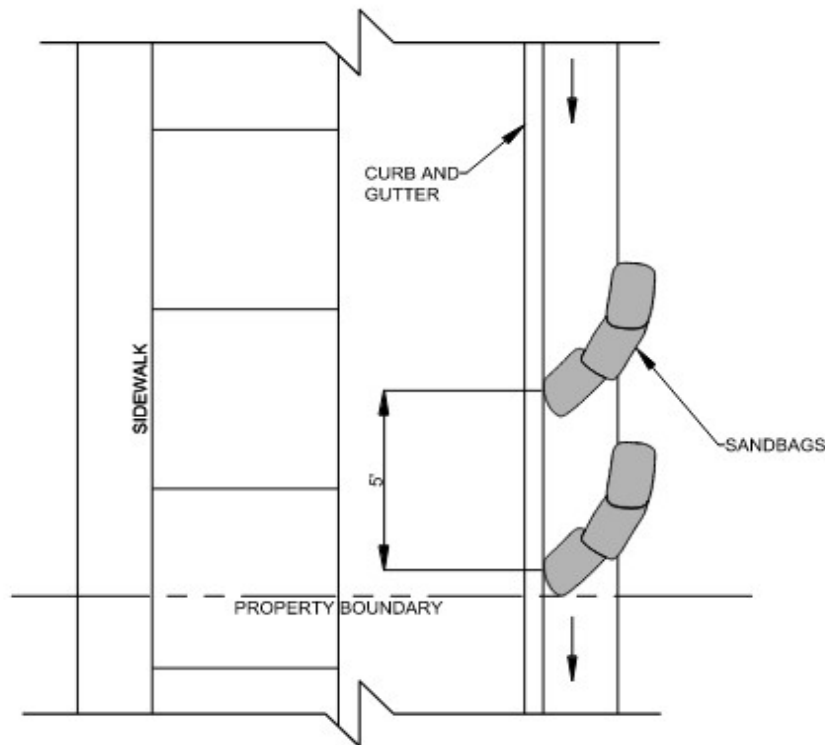

### **APPLICATION**

- This BMP allows sediment laden storm water to be filtered by the gutter dam minimizing sediment from reaching downstream inlets.
- This BMP allows for runoff by-pass during intense storm events but when adequately maintained can minimize sediment by-pass common with many inlet cover only BMPs. Inlet cover only BMPs should have secondary containment built in or coupled with downstream BMPs to contain sediment and debris by-pass.
- Use Gutter Dam BMP when the project is expected to contain its impact from other operators downstream BMPs. This is a common concern between operators when multiple independent builders are building homes in the same subdivision.
- Warning: This BMP is easily damaged by vehicles that park along the curb and gutter, and by snow removal operations.

### **INSTALLATION/USE PROCEDURES**

- Install 6" min diameter sand or gravel bags. Double up bags as necessary.
- Install upstream of inlets.
- This gutter dam system is working when the first dam is holding more sediment than the downstream dams. When the sediment collection is about the same then something is wrong.
- This system can scour out easily and needs regular maintenance to be effective.

- Inform subcontractors and suppliers of the gutter dams placement to roadside parking from damaging the sand or gravel bags.
- Train SWPPP inspection and maintenance team
- This BMP is designed for 1/4" (~2yr 10min intensity) rain storm events.

### **OPERATOR BMP MODIFICATION OR REPLACEMENT**

- Operator is invited to propose an alternative BMP or modify this preferred BMP. The proposed BMP must match or exceed performance requirements as this preferred BMP. Any deviations from this preferred BMP must be reviewed and accepted by the oversight authority.
- Submit BMP modifications or replacements to the oversight authority for review; including but not limited to; Proprietary system literature, modified illustrations, any operation procedures and maintenance adjustments, etc.

### **MAINTENANCE/MANAGEMENT**

- Anticipate significant storm events, repair damage and remove sediment deposits prior to storm events that could scour sediment deposits from the gutter dam.
- Inspect, remove sediment and repair gutter dam regularly during the report period and following each storm event.
- Following storm events, the first dam should have more sediment than the downstream dams. When inspection shows failure persists, even with regular maintenance, a third dam should be installed. If the gutter dam system does not perform as intended, a different or additional BMP is warranted.
- Bring awareness to workforce and suppliers parking near the gutter dam.
- Check during storm events and prevent driving hazardous resulting from surface water conditions.

### **PERFORMANCE**

- A gutter dam system is expected to slow the flow of runoff in the gutter to allow for sediment deposition. Erosion control of non-stabilized sediment should be used in conjunction with a gutter dam system. This BMP should be utilized as a secondary control to erosion control BMPs.

It is considered a BMP failure when any of the following occur:

- When storm events less than 1/4" of rain results in significant scour an alternative BMP is warranted.
- When regular damage occurs to the gutter dam system due to traffic or snow operations an alternative BMP is warranted.
- When sediment deposits are equal to or greater in the downstream dam following storm events of 1/4" or less, the BMP is not adequate and warrants a different BMP.

### **REFERENCE:**

- CGP 2.2.10
- CPP 2.1.3

## BMP 19 - Inlet Filter with Gutter Dam Combo

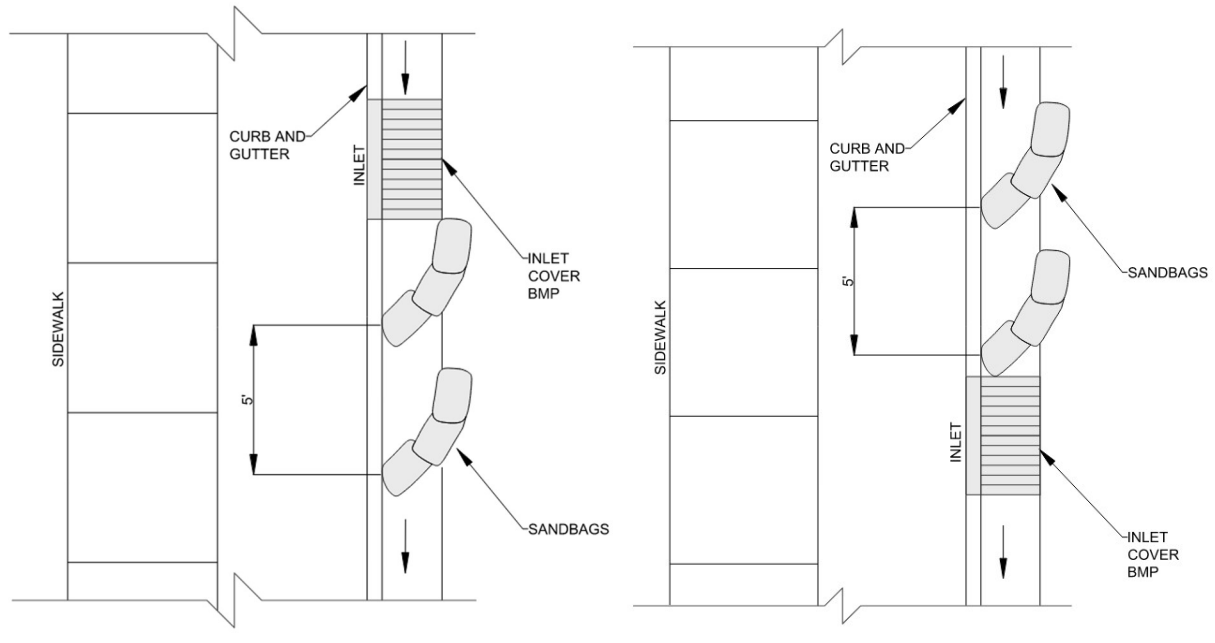

### **APPLICATION**

- This BMP allows sediment laden storm water to be filtered by inlet cover and the gutter dam. Installing the gutter dam on the downstream end of the inlet will increase filter effectiveness and reduce sediment and debris by-pass. This configuration can reduce passing higher volumes downstream.
- This BMP allows for runoff by-pass during intense storm events but when adequately maintained can minimize sediment reaching storm water inlets. Inlet cover only BMPs should have secondary containment built in.
- Use Inlet Filter Gutter Dam Combo BMP for at grade inlets.
- Warning: This BMP is easily damaged by vehicles that park along the curb and gutter, and by snow removal operations.

### **INSTALLATION/USE PROCEDURES**

- Install 6" min diameter sand or gravel bags. Double up bags as necessary.
- Install upstream of inlets.
- This gutter dam system is working when the first dam is holding more sediment than the downstream dams. When the sediment collection is about the same then something is wrong.
- This system can scour out easily and needs regular maintenance to be effective.
- Inform subcontractors and suppliers of the gutter dams placement to roadside parking from damaging the sand or gravel bags.
- Train SWPPP inspection and maintenance team
- This BMP is designed for 1/4" (~2yr 10min intensity) rain storm events.

### **OPERATOR BMP MODIFICATION OR REPLACEMENT**

- Operator is invited to propose an alternative BMP or modify this preferred BMP. The proposed BMP must match or exceed performance requirements as this preferred BMP. Any deviations from this preferred BMP must be reviewed and accepted by the oversight authority.
- Submit BMP modifications or replacements to the oversight authority for review; including but not limited to; Proprietary system literature, modified illustrations, any operation procedures and maintenance adjustments, etc.

### **MAINTENANCE/MANAGEMENT**

- Anticipate significant storm events, repair damage and remove sediment deposits prior to storm events that could scour sediment deposits from the gutter dam.
- Inspect, remove sediment and repair gutter dam regularly during the report period and following each storm event. Check for out of place or broken bags, and torn or punctured fabric.
- Following storm events, the first dam should have more sediment than the downstream dams. When inspection shows failure persists, even with regular maintenance, a third dam should be installed. If the gutter dam system does not perform as intended, a different or additional BMP is warranted.
- Inspect for sediments and remove with shovel and broom or vacuum tools.
- When fabric removal or replacement results in sediment dropping into the inlet, use hydro vacuum machinery or safely remove by other means
- Bring awareness to workforce and suppliers parking near the gutter dam.
- Check during storm events and prevent driving hazardous resulting from surface water conditions.

### **PERFORMANCE**

- A gutter dam system is expected to slow the flow of runoff in the gutter to allow for sediment deposition. Erosion control of non-stabilized sediment should be used in conjunction with a gutter dam system. This BMP should be utilized as a secondary control to erosion control BMPs.

It is considered a BMP failure when any of the following occur:

- When storm events less than ¼" of rain results in significant scour an alternative BMP is warranted.
- When regular damage occurs to the gutter dam system due to traffic or snow operations an alternative BMP is warranted.
- When sediment deposits are equal to or greater in the downstream dam following storm events of 1/4" or less, the BMP is not adequate and warrants a different BMP.

### **REFERENCE:**

- CGP 2.2.10
- CPP 2.1.3

## BMP 20- Solid Waste Management

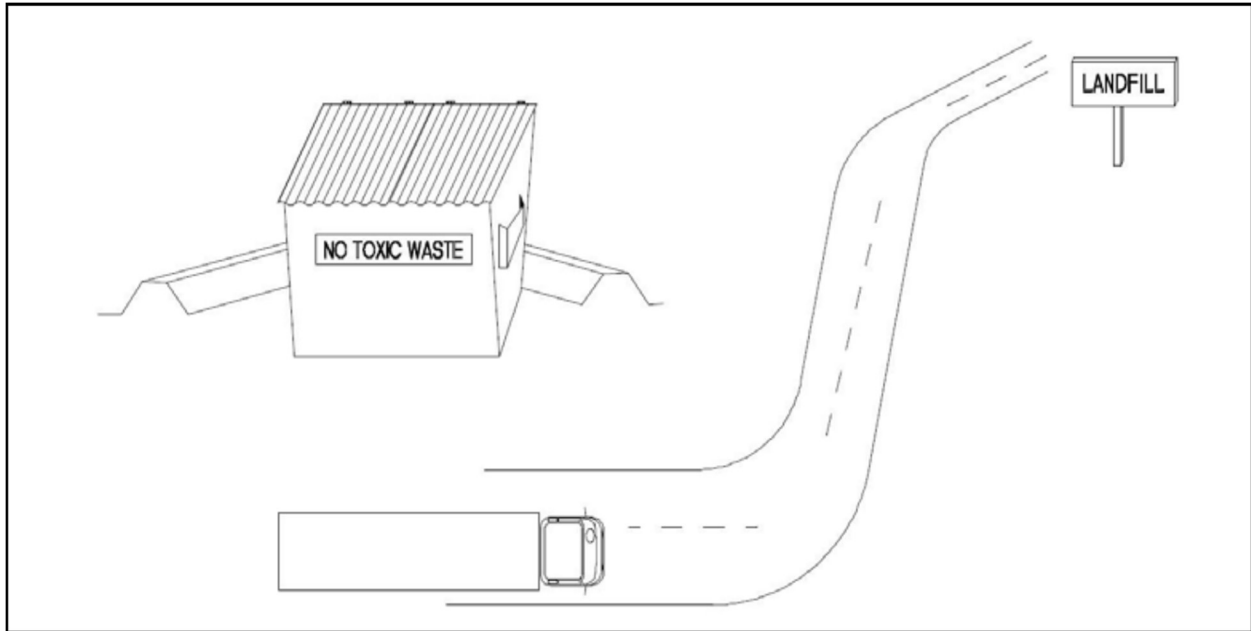

### **APPLICATION**

- This BMP is necessary when construction activities generate solid waste that needs to be collected and disposed of properly to prevent environmental contamination.
- Use this BMP when: The site generates solid waste, including packaging materials, scrap construction materials, masonry products, timber, pipe and electrical cuttings, plastics, styrofoam, concrete, demolition debris; and other trash or building materials that could potentially contaminate stormwater if not managed correctly.

### **INSTALLATION/USE PROCEDURES**

- **Selection Criteria:** Use durable, watertight containers (e.g., dumpster, trash receptacle) that are appropriately sized for the volume of waste generated on-site.
- **Placement:** position dumpsters on a flat, stabilized surface, away from storm drains and water bodies. Identify these locations on the site plan.
- **Usage:** ensure all construction waste is placed inside the dumpster. Do not overfill; waste should not extend beyond the sides or top of the dumpster. Do not dispose of liquids in this BMP. Most dumpsters and garbage trucks are not water tight.
- **Containment:** Provide containment or cover for waste that is blowable or that can leach nutrients, metals, pesticides, herbicides, oil, grease, bacteria, or other pollutants.
- **Segregation:** separate hazardous waste from non-hazardous waste and use appropriately labeled and secured containers for hazardous materials.

- Locate on parking pad or next to track-pad to prevent track-out when servicing. Show location on site BMP map.
- Do not install in roadways without approval of local municipality. This usually means obtaining a local right-of-way encroachment permit or equal to stage dumpsters in right-of-ways.
- Train workforce.

### **OPERATOR BMP MODIFICATION OR REPLACEMENT**

- Operator is invited to propose an alternative BMP or modify this preferred BMP. The proposed BMP must match or exceed performance requirements as this preferred BMP. Any deviations from this preferred BMP must be reviewed and accepted by the oversight authority.
- Submit BMP modifications or replacements to the oversight authority for review; including but not limited to; Proprietary system literature, modified illustrations, any operation procedures and maintenance adjustments, etc.

### **MAINTENANCE/MANAGEMENT**

- Ensure the workforce is informed about proper waste disposal procedures and the importance of maintaining the integrity of waste management BMPs.
- Operator is expected to modify the solid waste management system, location and capacity when necessary as site conditions and operations warrant.
- Inspect dumpsters for leaks, damage, and proper cover.
- Collect any trash around the construction site daily and deposit it in the waste container at designated collection areas.
- Arrange for regular waste removal to a licensed facility often enough to prevent overfilling.
- Contain and clean up spilled waste or overflow immediately.

### **PERFORMANCE**

A solid waste management BMP is considered effective if:

- All construction and domestic waste generated is contained
- No incidents of dumpster overflow or leaks
- No visible waste or debris around the construction site or dumpster area

### **REFERENCE**

- CGP 2.3.3 (e).

## **BMP 21- Chemical/Hazardous Materials Management**

### **APPLICATION**

- Use Chemical/Hazardous Materials Management BMP when chemicals or hazardous materials are used or stored at the construction site.

### **INSTALLATION/USE PROCEDURES**

- Any Chemical/Hazardous Materials storage on site that requires a BMP must be approved by the Municipality before commencement of storage.
- Store chemicals and/or other hazardous materials in sealed, clearly labeled containers.
- Safety Data Sheets (SDS) specific to each chemical must be accessible on site.
- When chemicals/hazardous materials are not in use, store materials in such a way that they are not exposed to stormwater or runoff. (covered and off the ground)
- Storage and use areas must be located away from waters of the state, sensitive areas, and storm water conveyance systems
- Submit illustration or detail for secondary containment system when secondary containment and/or cover is required (containers more than 55 gallons); such as drip pan, spill containment pallets, or spill berm with impermeable liner.
- Attach a spill plan and provide a spill kit in good working condition sufficient to address small spills and protect water quality.

### **OPERATOR BMP MODIFICATION OR REPLACEMENT**

- Operator is invited to propose an alternative BMP or modify this preferred BMP. The proposed BMP must match or exceed performance requirements as this preferred BMP. Any deviations from this preferred BMP must be reviewed and accepted by the oversight authority.
- Submit BMP modifications or replacements to the oversight authority for review; including but not limited to; Proprietary system literature, modified illustrations, any operation procedures and maintenance adjustments, etc.

### **MAINTENANCE/MANAGEMENT**

- Train employees and subcontractors in chemical/hazardous materials BMPs.
- Regularly inspect the chemical storage area and the construction site for evidence of spills
- Spills must be properly cleaned up with dry clean-up methods only.
- For spills that occur on permeable surfaces, remove contaminated material before leaching occurs and dispose according to manufacturer's recommended method of disposal and in compliance with Federal, State, Tribal, and local requirements
- Large spills must be documented and reported according to Section 2.3.6 of the CGP.
- Keep ample supplies of spill cleanup materials on-site and perform any repairs necessary to contain chemicals appropriately immediately.



- Dispose of expired or used up hazardous materials in accordance with the manufacturer's recommended method of disposal and in compliance with Federal, State, Tribal, and local requirements

### **PERFORMANCE**

- This BMP is expected to contain chemical/hazardous materials in such a way that it cannot pollute the environment.
- No pollutants are allowed to reach storm water conveyance systems or waters of the state

### **REFERENCE**

- CGP 2.3.3

## BMP 22- Onsite Equipment Fueling



### **APPLICATION**

- Use when fixed onsite fueling tanks are planned.

### **INSTALLATION/USE PROCEDURES**

- Any Fueling Materials storage on site that requires a BMP must be approved by the Municipality before commencement of storage.
- Locate fueling operations a minimum of 50 feet from receiving waters, constructed or natural site drainage features, and storm drain inlets. If infeasible due to site constraints, store containers as far away from these features as the site permits. If site constraints prevent you from storing containers 50 feet away from the features identified, you must document in your SWPPP the specific reasons why the 50-foot setback is infeasible.
- Store fuels in sealed, clearly labeled containers.
- Containers must be covered and/or have secondary containment (curbing, spill berms, dikes, spill containment pallets, double-walled storage tank)
- Submit illustration or detail for secondary containment of fuel containers and secondary containment used during active fueling (drip pan, drop cloth, etc.)
- Discourage topping-off of fuel tanks.
- Carry out all Federal and State requirements regarding stationary above ground storage tanks. (40 CF Sub. J) Avoid mobile fueling of mobile construction equipment around the site; rather, transport the equipment to designated fueling areas.
- Create and attach a Spill Plan specific to the project.

- If you fuel many vehicles or pieces of equipment, consider using an off-site fueling station. These areas are better equipped to handle fuel and spills properly.
- Provide a copy of your off-site written policy to the oversight authority for review

### **OPERATOR BMP MODIFICATION OR REPLACEMENT**

- Operator is invited to propose an alternative BMP or modify this preferred BMP. The proposed BMP must match or exceed performance requirements as this preferred BMP. Any deviations from this preferred BMP must be reviewed and accepted by the oversight authority.
- Submit BMP modifications or replacements to the oversight authority for review; including but not limited to; Proprietary system literature, modified illustrations, any operation procedures and maintenance adjustments, etc.

### **MAINTENANCE/MANAGEMENT**

- Fuel equipment in designated areas only
- Train employees and subcontractors in proper fueling and cleanup procedures.
- Regularly check for leaks and damage including but not limited to: tanks, hoses, and secondary containment.
- Keep ample supplies of spill cleanup materials on-site and perform any repairs necessary to contain fuel appropriately immediately.
- If spill occurs, use dry clean-up methods and dispose of spill clean-up materials to a proper licensed facility.
- Large spills must be documented and reported according to Section 2.3.6 of the CGP.

### **PERFORMANCE**

- Onsite equipment fueling BMPs are expected to protect stormwater to the extent that no fuel, oil, or solvents are allowed to pollute waters of the state or storm water conveyances.

### **REFERENCE**

- CGP 2.3.1

## BMP 23- Water Bars

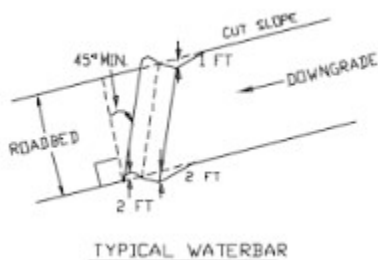
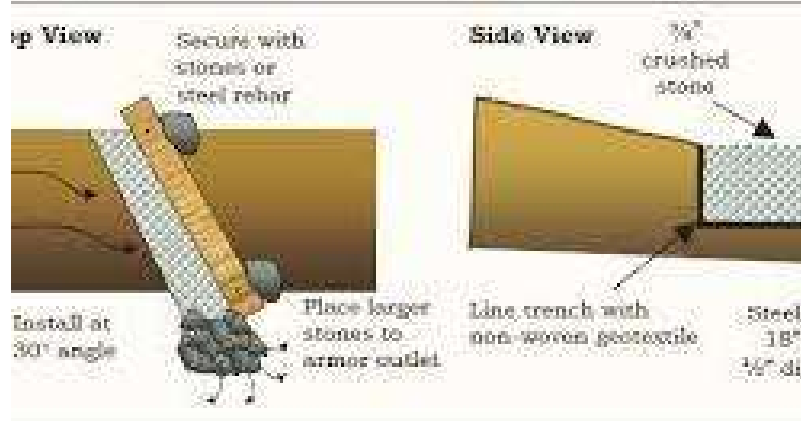
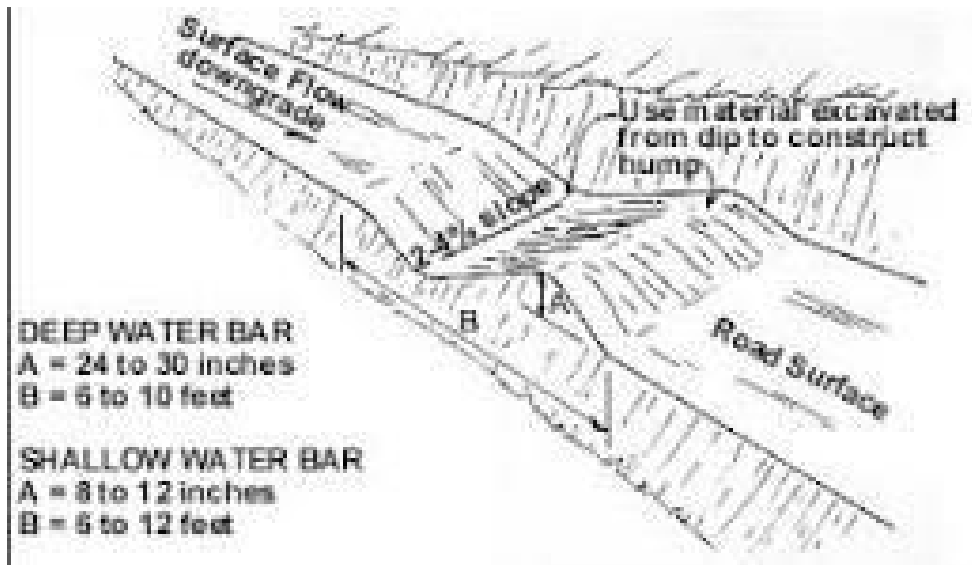

### **APPLICATION**

Water Bars may be used as a means of erosion control when:

- Clearing right-of-way and construction of access for power lines, poplins, and other similar installations that often require long narrow rights-of-way over sloping terrain.
- Disturbance and compaction promote gully formation in these cleared strips by increasing the volume and velocity of runoff
- Gully formation may be especially severe in tire tracks and ruts. To prevent gullying, runoff can often be diverted across the width of the right-of-way to

undisturbed areas by using small predesigned diversions generally referred to here as water bars.

### **INSTALLATION/USE PROCEDURES**

- Give special consideration to each outlet area individually, as well as to the cumulative effect of added diversions. Use gravel to stabilize the diversion where significant vehicular traffic is anticipated.
- Design the height of the Water Bar with the slope in mind to effectively divert the volume needed.
- Design the base width of the ridge with the slope and volume of water diverted in mind.
- Locate well-vegetated and stable areas to use natural drainage systems and to discharge into well-vegetated stable areas.
- During a rain event ensure that the installed Water Bars are effective in diverting the runoff away from the road, or path and that the discharge areas are effective at handling the volume of water being diverted.

### **OPERATOR BMP MODIFICATION OR REPLACEMENT**

- Operator is invited to propose an alternative BMP or modify this preferred BMP. The proposed BMP must match or exceed performance requirements as this preferred BMP. Any deviations from this preferred BMP must be reviewed and accepted by the oversight authority.
- Submit BMP modifications or replacements to the oversight authority for review; including but not limited to; Proprietary system literature, modified illustrations, any operation procedures and maintenance adjustments, etc.

### **MAINTENANCE/MANAGEMENT**

- Periodically inspect right-of-way diversions for wear and after every heavy rainfall for erosion damage.
- Immediately remove sediment from the flow area and repair the dike.
- Check outlet areas and make timely repairs as needed.
- When permanent road drainage is established and the area above the temporary right-of-way diversion is permanently stabilized, remove the dikes and fill the channel to blend with the natural ground, and appropriately stabilize the disturbed area.

### **PERFORMANCE**

It is considered a Water Bar management failure when any of the following occurs:

- Water is not being properly diverted from the intended area.
- Sediment is built up in diverted flow areas and needs to be maintained.

### **REFERENCE**

2.1, 2.2, 2.3

## BMP 24- Portable Sediment Tank

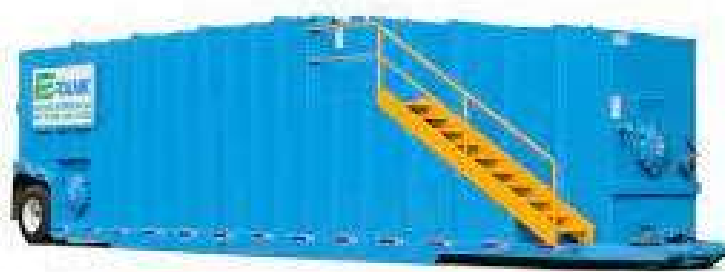

### **APPLICATION**

- This BMP is necessary when construction activities generate significant amounts of sediment-laden water that needs to be managed to prevent environmental contamination.
- Use this BMP when: The site requires the temporary storage and treatment of sediment-laden water due to construction activities such as excavation, dewatering, or stormwater runoff collection.

### **INSTALLATION/USE PROCEDURES**

- **Placement:** position the portable sediment tank (frac tank) on a flat, stabilized surface, away from storm drains and water bodies. Identify these locations on the site plan.
- **Connection:** ensure all hoses and connections are secure and leak-free. Properly connect the inlet and outlet hoses to direct sediment-laden water into the tank.
- **Filling:** gradually fill the tank with sediment-laden water, allowing sediments to settle out. Avoid overfilling the tank.
- **Sediment removal:** periodically remove accumulated sediments from the tank according to proprietary specifications to maintain capacity and effectiveness. Follow appropriate disposal methods for the removed sediments.
- **Discharge:** discharge the treated water in compliance with local regulations, ensuring that it meets the required water quality standards.
- **Training:** ensure the workforce is informed about the correct operation and maintenance procedures for portable sediment tank (frac tank).

### **OPERATOR BMP MODIFICATION OR REPLACEMENT**

- Operator is invited to propose an alternative BMP or modify this preferred BMP. The proposed BMP must match or exceed performance requirements as this preferred BMP. Any deviations from this preferred BMP must be reviewed and accepted by the oversight authority.

- Submit BMP modifications or replacements to the oversight authority for review; including but not limited to; Proprietary system literature, modified illustrations, any operation procedures and maintenance adjustments, etc.

### **MAINTENANCE/MANAGEMENT**

- Inspect the portable sediment tank (frac tank) and associated equipment for leaks, damage, and proper functioning.
- Ensure that sediment levels are monitored and sediments are removed as needed to maintain tank capacity.
- Applicant is expected to modify the portable sediment tank system, location and capacity when necessary as site conditions and operations warrant.

### **PERFORMANCE**

- Ensure that the discharge from the frac tank meets local, state, and federal water quality standards for sediment and turbidity. Any discharge with visible sediment or cloudiness constitutes failure and requires immediate corrective action.
- Any leak or spill around the tank area indicates BMP failure.
- Sediment within the tank must be kept below the manufacturer's recommended level.

### **REFERENCE**

- CGP 2.2.12, 7.3.5, A.2.4

## BMP 25 - Sediment Basin

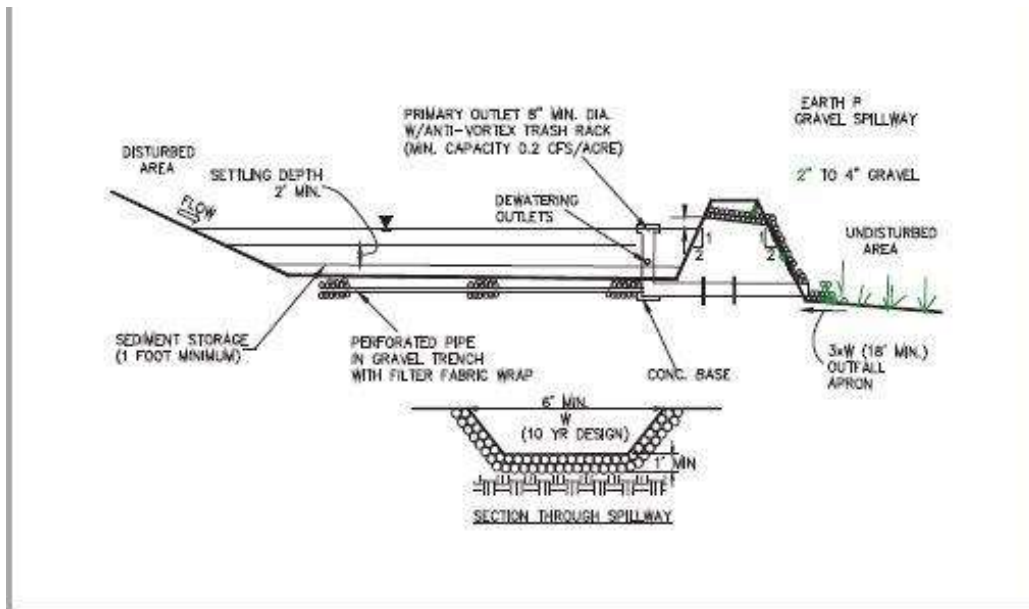

### **APPLICATION**

Sediment basins serve as treatment devices which can be used on a variety of project types.

They are normally used in construction projects where:

- Large areas of land drain to the basin
- At the outlet of disturbed watersheds 10 acres or larger
- At the outlet of smaller watersheds as necessary
- Where post construction basins will be located
- for disturbed upstream drainage areas of 5 acres or more

### **INSTALLATION/USE PROCEDURES**

- Determine the number of basins needed. In some cases, it is more effective to have multiple smaller basins versus one large basin. This is particularly important in areas with larger-grained sediments. In addition, potential damage from basin failure can be minimized by using multiple smaller basins, versus one large basin.
- Whenever possible, construct the sedimentation basins before clearing and grading work begins.
- Construct sediment basins at locations that are accessible for cleanout.
- Situate the basin or impoundment outside of any water of the state and any natural buffers.
- Design the basin or impoundment to avoid collecting water from wetlands or high ground water.
- Design the basin or impoundment to provide for either:
  - (1) The calculated volume of runoff from the 2-year, 24-hour storm; or
  - (2) 3600 cubic feet per acre drained.
- Utilize outlet structures that withdraw water from near the surface of the sediment basin or similar impoundment, unless infeasible.



- Use erosion controls and velocity dissipation devices to prevent erosion at inlets and outlets.
- Sediment basins and ponds must be installed only within the property limits where failure of the structure would not result in loss of life, damage to homes or buildings, or interruption of use or service of public roads or utilities.
- Sediment basins and ponds are attractive to children and can be very dangerous. Local ordinances regarding health and safety must be adhered to. If fencing of the pond is required, the type of fence and its location should be shown on the Stormwater Pollution Prevention Plan (SWPPP).
- Because of additional detention time, sediment basins may be capable of trapping smaller sediment particles than traps. However, they are most effective when used in conjunction with other BMPs such as seeding or mulching.
- Sediment basins can be converted to permanent structures after completion of the construction project. Remove all excess sediment from the basin. The containment volume must meet the design specifications of the approved plan set. The inside of a permanent sediment basin should be stabilized to meet local and UPDES requirements.

#### **OPERATOR BMP MODIFICATION OR REPLACEMENT**

- Operator is invited to propose an alternative BMP or modify this preferred BMP. The proposed BMP must match or exceed performance requirements as this preferred BMP. Any deviations from this preferred BMP must be reviewed and accepted by the oversight authority.
- Submit BMP modifications or replacements to the oversight authority for review; including but not limited to; Proprietary system literature, modified illustrations, any operation procedures and maintenance adjustments, etc.

#### **MAINTENANCE/MANAGEMENT**

- Inspect after each rainfall event and at a minimum as part of any regularly scheduled inspections.
- Repair any damage to the berm, spillway, sidewalls and outlet structures or mechanisms.
- Remove accumulated sediment to maintain at least one-half of the design capacity and conduct all other appropriate maintenance to ensure the basin or impoundment remains in effective operating condition.
- Check outlet for sedimentation/erosion of downgradient area and remediate and/or install downgradient BMPs as necessary.

#### **PERFORMANCE**

- Sediment basins are at best only 70-80 percent effective in trapping sediment which flows into them. Therefore, they should be used in conjunction with erosion control practices such as temporary seeding, mulching, diversion dikes, etc. to reduce the amount of sediment flowing into the basin.

- A type of outlet being used with increasing frequency is the floating skimmer. Some early tests indicate that the skimmer (which draws water only from the surface) might be more effective at retaining sediment in the basin than the standard riser and barrel configuration.

#### **REFERENCE**

- CGP 2.2.12, 7.3.5
- Drainage Design Manual for City
- Salt Lake County Best Management Practices for Construction Activities

## BMP 26- Rock Track Out Pad

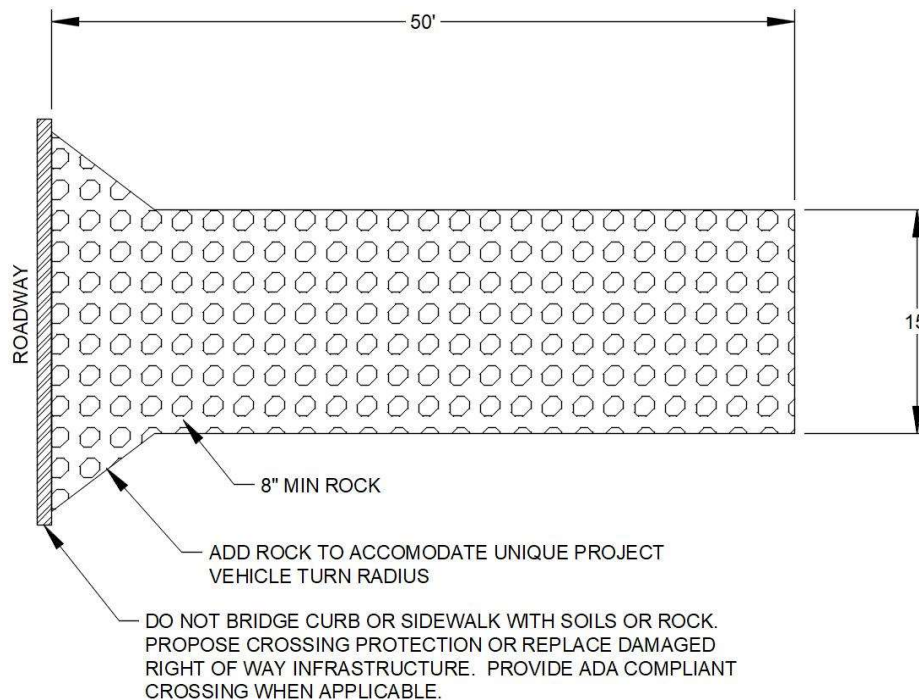

### **APPLICATION**

- Use this BMP when vehicles and equipment operations require egress from the project property to decrease the amount of debris leaving the site via vehicle tracking.
- Particularly applicable in wet conditions in which sediment sticks more easily to tires/tracks.

### **INSTALLATION/USE PROCEDURE**

- Determine the ingress/egress location(s) allowed by the oversight authority and show them on the site plan.
- Use 8" rock for the track out pad at a minimum depth of 8" and use dimensions described in the illustration above.
- Workforce and subcontractors must utilize the track out pad when leaving the construction site.
- Move vehicles forward and in reverse until mud is removed from tires.
- Stop, for rocks wedged in dual tires and remove any unremoved mud and wedged rocks.
- Ensure the workforce is trained regarding track-out BMP requirements.
- Use of Sweeping BMP is still usually necessary at the end of the day at minimum.

### **OPERATOR BMP MODIFICATION OR REPLACEMENT**

- Operator is invited to propose an alternative BMP or modify this preferred BMP. The proposed BMP must match or exceed performance requirements

as this preferred BMP. Any deviations from this preferred BMP must be reviewed and accepted by the oversight authority.

- Submit BMP modifications or replacements to the oversight authority for review; including but not limited to; Proprietary system literature, modified illustrations, any operation procedures and maintenance adjustments, etc.

### **MAINTENANCE/MANAGEMENT**

- Rake, refresh or wash rock as necessary when space between rocks is inundated with mud.
- Add, extend or replace rock as necessary to achieve performance criteria results.
- Train workforce when BMP improper use is recognized.
- When sediment, rock, or gravel track out occurs due to BMP failure or misuse, debris must be removed from roadways according to the CGP criteria.
  - Street clean-up operations are separate from this Rock Track Out Pad BMP, but necessary to address unacceptable track out that may occur.

### **PERFORMANCE:**

- Slick conditions, slurry, mud chunks, rocks, gravel, water quality risk and driver hazards constitute BMP failure and require immediate sufficient action.
- Light tracking is expected and requires regular maintenance but not usually immediate action. Light tracking is defined as minor residual dirt that can't be picked up by a square nose shovel.
  - Remove/sweep prior to unsafe and wet conditions or end of workday, whichever is first.

### **REFERENCE:**

- CGP 2.2.4, 5.1, 5.2.1
- CPP 2.4.1

## BMP 27- Wheel Wash

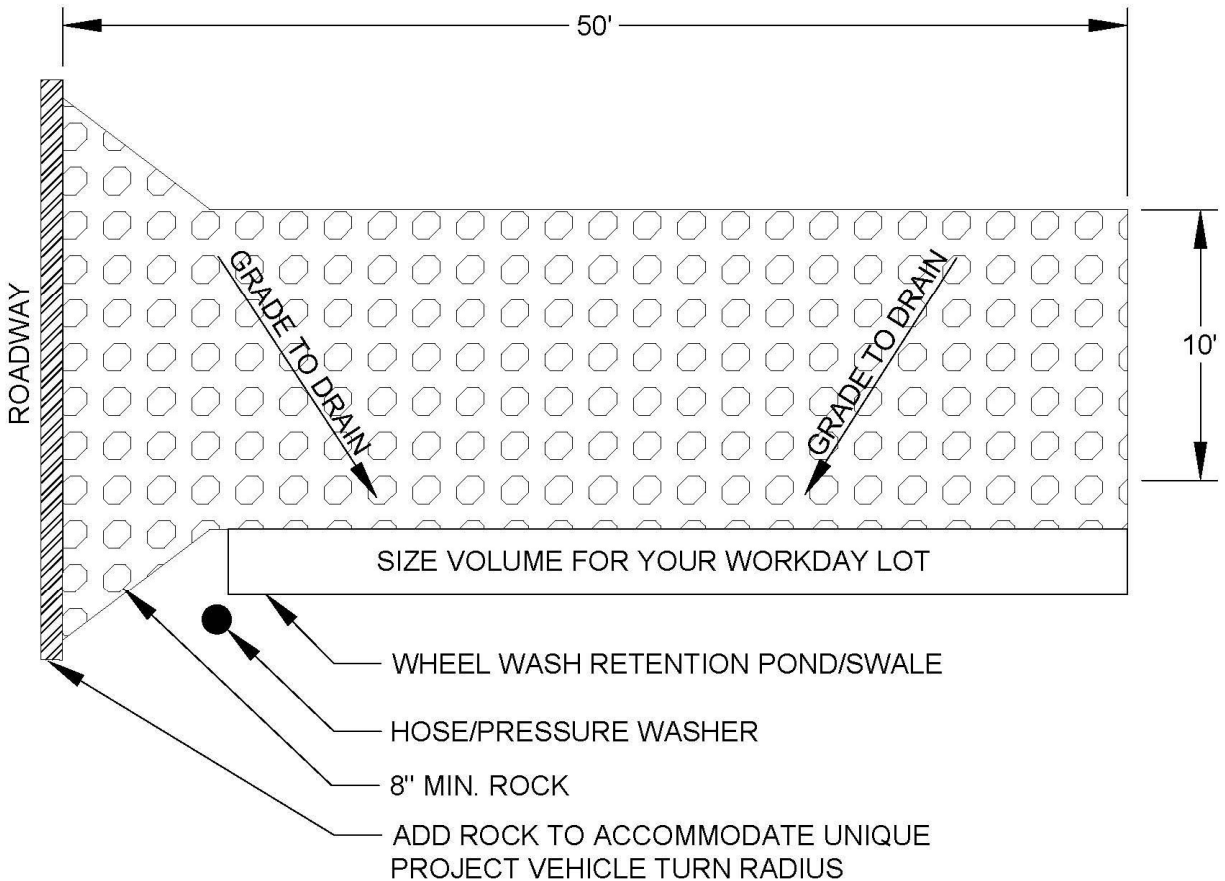

### **APPLICATION**

- Use this BMP when vehicles and equipment operations require egress from the project property to decrease the amount of debris leaving the site via vehicle tracking.
- Use wheel wash BMP when mud needs to be removed from tires.
- Wheel washes are a logical redundant option during very wet conditions when other wheel agitation type tire mud management systems are not effective.

### **INSTALLATION/USE PROCEDURE**

- Determine the ingress/egress location(s) allowed by the oversight authority and show them on the site plan.
- Do not bypass the wheel wash area when track out prevention is necessary.
- Wash all wheels with a hose or pressure washer provided. Pull forward as necessary to remove all mud from tires and tread.
- Check for rocks wedged in dual tires and remove.
- Identify the necessary retention volume needed for wash waters and attach to this BMP.
- Ensure the workforce is trained regarding track-out BMP requirements.

### **OPERATOR BMP MODIFICATION OR REPLACEMENT**

- Operator is invited to propose an alternative BMP or modify this preferred BMP. The proposed BMP must match or exceed performance requirements as this preferred BMP. Any deviations from this preferred BMP must be reviewed and accepted by the oversight authority.
- Submit BMP modifications or replacements to the oversight authority for review; including but not limited to; Proprietary system literature, modified illustrations, any operation procedures and maintenance adjustments, etc.

### **MAINTENANCE/MANAGEMENT**

- Rake or wash rock as necessary when BMP is not working.
- Remove pond/swale sedimentation at 50% capacity.
- Expand the wash water basin as necessary to contain the retention volume required.
- Do not wash wheels anywhere on site except at the designed wheel wash area that has a retention pond to retain and treat wash waters.
- Train workforce when BMP improper use is recognized.
- When sediment, rock, or gravel track out occurs due to BMP failure or misuse, debris must be removed from roadways according to the CGP criteria.
  - Street clean-up operations are separate from this wheel wash BMP, but necessary to address unacceptable track out that may occur.

### **PERFORMANCE:**

- The Wheel Wash BMP is expected to greatly minimize the risk of excessive track out onto roadways and also utilizes sediment deposition in the wash water retention pond.
- Slick conditions, slurry, mud chucks, rocks, gravel, water quality risk and driver hazards constitute BMP failure and require immediate sufficient action.
- Light tracking is expected and requires regular maintenance but not usually immediate action. Light tracking is defined as minor residual dirt that can't be picked up by a square nose shovel.
  - Remove/sweep prior to unsafe and wet conditions or end of workday, whichever is first.

### **REFERENCE:**

- CGP 2.2.4, 5.1, 5.2.1
- CPP 2.4.1

## BMP 28 - Parking Pad & Supplier Access

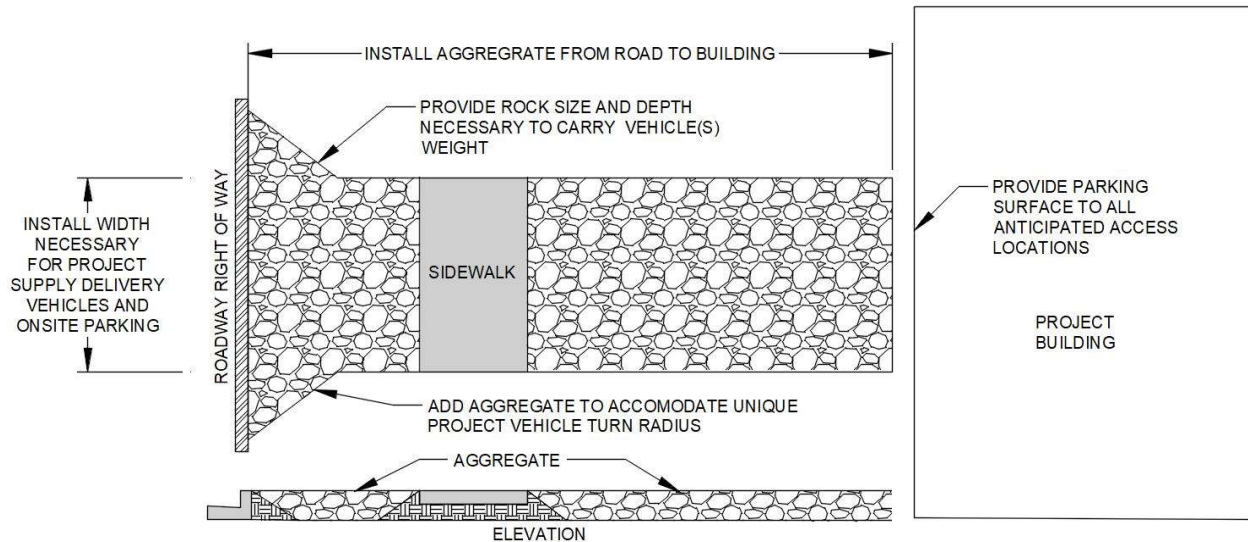

### **APPLICATION**

- Use a parking pad for supply delivery vehicles, tool drop off and onsite project parking etc.
- Use this BMP to *prevent* mud from sticking to tires. This BMP will not remove mud sticking to tires.

### **INSTALLATION/USE PROCEDURES**

- Determine where supplies and tools need to be delivered or dropped off and show the delivery area on the site plan. Coordinate with oversight authority for any prohibited access locations.
- Do not drive beyond the parking pad.
- Size pad to accommodate project supply vehicles and any necessary onsite parking. Attach illustration of specific dimensions for the parking pad and gravel/rock specific to the project needs with this BMP detail.
- Ensure the workforce is trained regarding proper use and maintenance of the parking/delivery pad.

### **OPERATOR BMP MODIFICATION OR REPLACEMENT**

- Operator is invited to propose an alternative BMP or modify this preferred BMP. The proposed BMP must match or exceed performance requirements as this preferred BMP. Any deviations from this preferred BMP must be reviewed and accepted by the oversight authority.
- Submit BMP modifications or replacements to the oversight authority for review; including but not limited to; Proprietary system literature, modified illustrations, any operation procedures and maintenance adjustments, etc.

### **MAINTENANCE/MANAGEMENT**



- Refresh parking/access pad as necessary when BMP is not effective at preventing mud from sticking to tires.
- Add, extend or replace rock as necessary to achieve performance criteria results.
- Train workforce when BMP improper use is recognized.
- When sediment, rock, or gravel track out occurs due to BMP failure or misuse, debris must be removed from roadways according to the CGP criteria.
  - Street clean-up operations are separate from this Parking Pad BMP, but necessary to address unacceptable track out that may occur.

## **PERFORMANCE**

- The parking pad and supplier access gravel pad is expected to reduce vehicle contact with exposed sediment on site.
- In addition, it also acts as a visual marker for suppliers to know where to make deliveries, increasing work site operation efficiency.
- Slick conditions, slurry, mud chunks, rocks, gravel, water quality risk and driver hazards constitute BMP failure and require immediate sufficient action.

## **REFERENCE:**

- CGP 2.2.4, 5.1, 5.2.1
- CPP 2.4.1



## BMP 29 - Manual Mud Removal

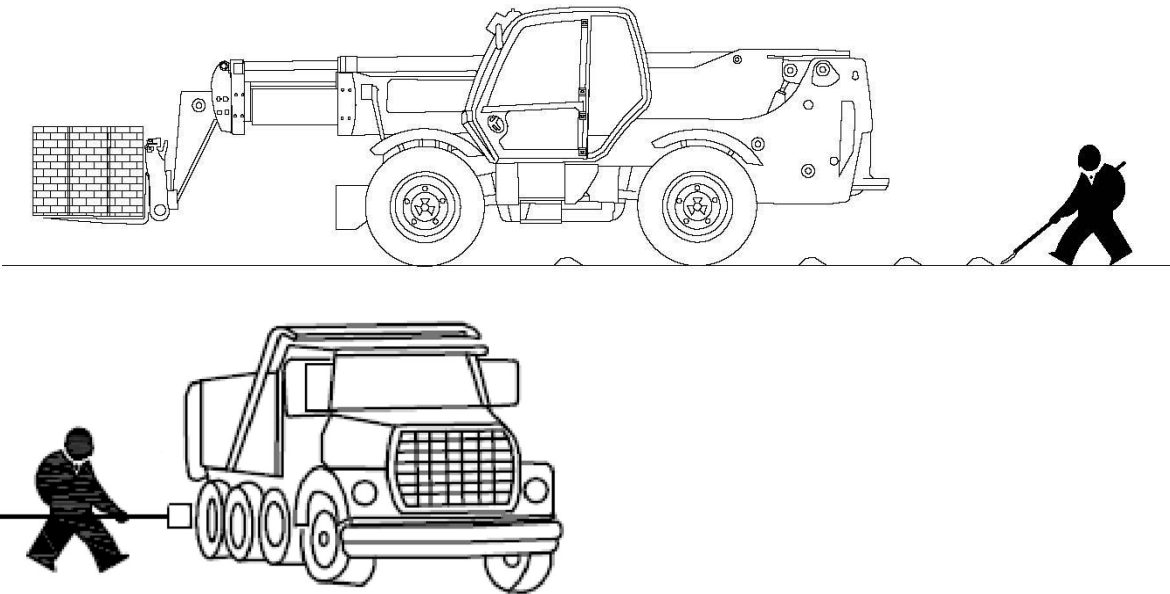

### **APPLICATION**

- Use this BMP when vehicles and equipment operations require egress from the project property during wet conditions resulting in mud sticking to vehicle tires and tracks.
- Use this BMP when non-regular egress is necessary or using the primary track out BMP is not practical for an unusual situation.
- Use this BMP as a redundant BMP when the primary track out BMP(s) is not working.
- Use this BMP for short transfer of vehicles for short distances, e.g. across the street.

### **INSTALLATION/USE PROCEDURES**

- Stop before exiting the site and use a square nose shovel or stiff broom to remove mud from tires and remove mud tracks when applicable.
  - When manually removing mud on pavement, shovel and sweep with each track out occurrence and always perform this BMP when incidents are upstream of inlets.
- Check for and remove rocks wedged in dual tires.
- Ensure the workforce is trained regarding mud removal and clean-up of trackout BMP requirements.
- Use of Sweeping BMP is still usually necessary at the end of day minimum.

### **OPERATOR BMP MODIFICATION OR REPLACEMENT**

- Operator is invited to propose an alternative BMP or modify this preferred BMP. The proposed BMP must match or exceed performance requirements as this preferred BMP. Any deviations from this preferred BMP must be reviewed and accepted by the oversight authority.

- Submit BMP modifications or replacements to the oversight authority for review; including but not limited to; Proprietary system literature, modified illustrations, any operation procedures and maintenance adjustments, etc.

### **MAINTENANCE/MANAGEMENT**

- When removing mud from tires or tracks on pavement sweep prior to wet conditions or end of day, whichever comes first.
- Train workforce when BMP improper use is recognized.
- When sediment, rock, or gravel track out occurs due to BMP failure or misuse, debris must be removed from roadways according to the CGP criteria.
  - Street clean-up operations are separate from this Manual Mud Removal BMP, but necessary to address unacceptable track out that may occur.

### **PERFORMANCE:**

- Slick conditions, slurry, mud chunks, rocks, gravel, water quality risk and driver hazards constitute BMP failure and require immediate sufficient action.
- Light tracking is expected and requires regular maintenance but not usually immediate action. Light tracking is defined as minor residual dirt that can't be picked up by a square nose shovel.
  - Remove/sweep prior to unsafe and wet conditions or end of workday, whichever is first.

### **REFERENCE:**

- CGP 2.2.4, 5.1, 5.2.1
- CPP 2.4.1

## BMP 30 - Track Vehicle Crossing

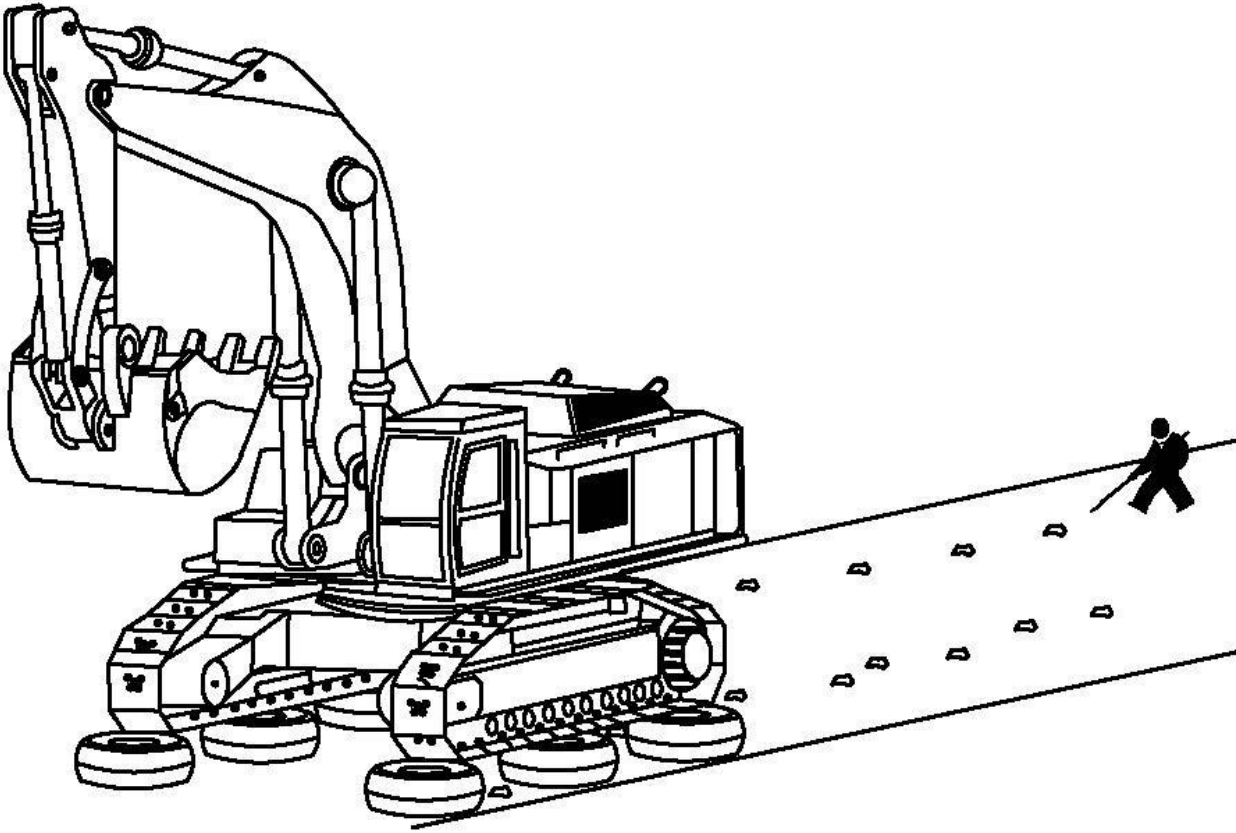

### **APPLICATION**

- Use when track vehicle road crossing for multiple project sites is planned.
- It is not practical to remove mud from most tracked construction equipment. Even track washing is usually impractical.

### **INSTALLATION/USE PROCEDURES**

- When road crossings are short distances, remove clumps with a square nose shovel and broom at each crossing. The clumps will be compacted to the road reducing vacuum sweeper effectiveness.
- When distant crossings are necessary, scraping or track washing BMPs are usually necessary. A machinery bucket blade can also work but follow up with a vacuum operated sweeper is also necessary.
- Protect roadway infrastructure from vehicle tracks. Placing tires beneath tracks is usually effective. Decide the track buffer method and attach your plan to this BMP.
- Ensure the workforce is trained regarding track-out BMP requirements.
- Use of Sweeping BMP is still usually necessary at the end of day minimum.

### **OPERATOR BMP MODIFICATION OR REPLACEMENT**

- Operator is invited to propose an alternative BMP or modify this preferred BMP. The proposed BMP must match or exceed performance requirements as this preferred BMP. Any deviations from this preferred BMP must be reviewed and accepted by the oversight authority.

- Submit BMP modifications or replacements to the oversight authority for review; including but not limited to; Proprietary system literature, modified illustrations, any operation procedures and maintenance adjustments, etc.

### **MAINTENANCE/MANAGEMENT**

- Regular sweeping is usually necessary daily. Shovels are intended to remove the dirt/mud clumps but will not move residual slurry that collects over multiple days.
- Train workforce when BMP improper use is recognized.
- When sediment, rock, or gravel track out occurs due to BMP failure or misuse, debris must be removed from roadways according to the CGP criteria.
  - Street clean-up operations are separate from this Track Vehicle Crossing BMP, but necessary to address unacceptable track out that may occur.

### **PERFORMANCE**

- Slick conditions, slurry, mud chucks, rocks, gravel, water quality risk and driver hazards constitute BMP failure and require immediate sufficient action.
- Light tracking is expected and requires regular maintenance but not usually immediate action. Light tracking is defined as minor residual dirt that can't be picked up by a square nose shovel.
  - Remove/sweep prior to unsafe and wet conditions or end of workday, whichever is first.

### **REFERENCE**

- CGP 2.2.4, 5.1, 5.2.1
- CPP 2.4.1

## **BMP 31 - Street Sweeping**

### **APPLICATION**

- A Sweeping BMP is necessary to address the immediate safety, water quality and complaint issues that exist resulting from vehicle track out.
- Sweeping BMPs do not eliminate the requirement for egress track out BMPs, but are necessary to compensate for the practical limitations of most egress track out BMPs.

### **INSTALLATION/USE PROCEDURES**

- Use vacuum type sweeping machinery.
- Anticipate end of day sweeping or multiple times a day as needed. The better the egress track out BMP the less sweeping operations are necessary.
- A Square nose shovel and broom are also always a good roadway sediment and debris removal option.
- Identify the sweeper hopper licensed dump location. Attach dump location information to this BMP.
- Ensure the workforce is trained regarding track-out BMP requirements.

### **OPERATOR BMP MODIFICATION OR REPLACEMENT**

- Operator is invited to propose an alternative BMP or modify this preferred BMP. The proposed BMP must match or exceed performance requirements as this preferred BMP. Any deviations from this preferred BMP must be reviewed and accepted by the oversight authority.
- Submit BMP modifications or replacements to the oversight authority for review; including but not limited to; Proprietary system literature, modified illustrations, any operation procedures and maintenance adjustments, etc.

### **MAINTENANCE/MANAGEMENT**

- Employ sweeping operations at the end of the workday and as necessary.
- Train workforce when BMP improper use is recognized.

### **PERFORMANCE:**

- Slick conditions, slurry, mud chucks, rocks, gravel, water quality risk and driver hazards constitute BMP failure and require immediate sufficient action.
- Light tracking is expected and requires regular maintenance but not usually immediate action. Light tracking is defined as minor residual dirt that can't be picked up by a square nose shovel.
  - Remove/sweep prior to unsafe and wet conditions or end of workday, whichever is first.

### **REFERENCE:**

- CGP 2.2.4, 5.1, 5.2.1
- CPP 2.4.1

## **BMP 32 - Fugitive Dust Control Plan**

### **APPLICATION**

- Dust control applies to any bare earth on the project that is at risk of being picked up by wind erosion.
- Dust suppression is necessary for all areas where vegetation is removed.
- A good BMP for dust management is to minimize and phase vegetation removal. See Phase Clearing BMP.

### **INSTALLATION/USE PROCEDURES**

- Attach a copy of the Fugitive Dust Control Plan and DAQ permit information
- Attach a copy of the Dust Control Plan Tools and details for suppression, including but not limited to equipment information, methods, and responsible party (inhouse or subcontracted)
- Attach a list of all dust generating operations, including but not limited to; vehicle traffic, dirt processing, load and haul, brick mason operations, etc.
- Ensure the workforce is trained regarding track-out BMP requirements.

### **OPERATOR BMP MODIFICATION OR REPLACEMENT**

- Operator is invited to propose an alternative BMP or modify this preferred BMP. The proposed BMP must match or exceed performance requirements as this preferred BMP. Any deviations from this preferred BMP must be reviewed and accepted by the oversight authority.
- Submit BMP modifications or replacements to the oversight authority for review; including but not limited to; Proprietary system literature, modified illustrations, any operation procedures and maintenance adjustments, etc.

### **MAINTENANCE/MANAGEMENT**

- Implement Fugitive Dust Control plan per DAQ permit.
- Train workforce when BMP improper use is recognized.

### **PERFORMANCE:**

- UAC section R307-309-5. Typically, this means no greater than 10% opacity at property boundaries.
- Any neighbor complaints warrants reevaluation of the effectiveness of the dust control plan and/or an inspection by the oversight authority.

### **REFERENCE:**

- UAC section R307-309-5
- CGP 2.2.6
- CPP 2.2.6

## **BMP 33 - Vegetation Removal Phasing**

### **APPLICATION**

- Erosion and dust suppression are necessary for all areas where vegetation is removed.
- Apply vegetation removal management to minimize dust and erosion risk. Many large projects can benefit from this BMP.

### **INSTALLATION/USE PROCEDURES**

- Attach a copy of phasing maps showing no disturbance areas for each phase. A vegetated buffer can also be utilized to provide erosion control along the outskirts of the project area.
- Ensure the workforce are informed regarding no disturbance areas.

### **OPERATOR BMP MODIFICATION OR REPLACEMENT**

- Operator is invited to propose an alternative BMP or modify this preferred BMP. The proposed BMP must match or exceed performance requirements as this preferred BMP. Any deviations from this preferred BMP must be reviewed and accepted by the oversight authority.
- Submit BMP modifications or replacements to the oversight authority for review; including but not limited to; Proprietary system literature, modified illustrations, any operation procedures and maintenance adjustments, etc.

### **MAINTENANCE/MANAGEMENT**

- Train workforce when encroachment into no disturbance areas are found. Update no disturbance maps and SWPPP document as relevant.
- Address encroachment exposures and add or amend BMPs to compensate for the exposure as necessary.

### **PERFORMANCE:**

- Encroachment of no disturbance phasing plan areas constitutes BMP non-compliance.

### **REFERENCE:**

- UAC section R307-309-5
- CGP 2.2.2, 2.2.9, 2.2.6, 7.3.2.f
- CPP 2.2.14

## **BMP 34 - Final Stabilization**

### **APPLICATION**

- Construction projects considered completed that will have bare, unimproved, erodible surfaces
- Projects with temporary exposed surfaces exceeding the CGP cover and time limits.
- A Final Stabilization Plan is necessary for all projects. The final stabilization CGP goal is when the final landscape plan achieves surface stabilization of 70% uniformly distributed cover by either finish grade mulch or established vegetation.

### **INSTALLATION/USE PROCEDURES**

- Attach a copy of the final landscaping plan, including but not limited to vegetation establishment periods.
- Attach a copy temporary vegetation, including but not limited to temporary seed plan, chemical treatment of erodible surfaces, erosion control blankets, etc.,
- Provide a list of all the SWPPP erosion, operation and fugitive dust BMPs that must remain in place through the final stabilization installation and establishment period.
- Ensure the workforce is informed of the final stabilization BMP requirements.

### **OPERATOR BMP MODIFICATION OR REPLACEMENT**

- Operator is expected to submit a site-specific final stabilization plan attached to this BMP. This may include: Proprietary system literature, illustrations, any operation procedures and maintenance required to achieve storm water pollution prevention and final stabilization.

### **MAINTENANCE/MANAGEMENT**

- Ensure all other SWPPP containment BMPs are installed, maintained and inspected throughout the installation of the final landscaping infrastructure and vegetation establishment period.
- Train workforce when final stabilization plan and site BMP non-containment is recognized.

### **PERFORMANCE:**

A Final Stabilization Plan is not effective when any of the following occurs:

- Erosion occurs beyond the disturbance boundary or sediment is leaving the site.
- A pollutant risk to water quality is present.
- Fugitive dust opacity exceeds DAQ Permit requirements which is usually opacity exceeding 10% at the property boundary.
- Any neighbor complaints warrants an inspection.



**REFERENCE:**

- UAC section R307-309-5
- CGP 2.2.6, 2.2.14, 2.2.14.a, 7.3.5.b
- CPP 2.2.14, 8.2.1

## **BMP 35 - Stockpile Management**

### **APPLICATION**

- Projects where topsoil is stripped and will be reused at a later phase
- Projects where any natural materials must be stored on site for use throughout the project
- Projects which have an offsite stockpile area

### **INSTALLATION/USE PROCEDURES**

- Provide staging/storage area location(s) on the BMP map.
- For offsite storage yard or stockpiles that are used in conjunction with the project, include appropriate storm water pollution prevention controls and BMPs in the SWPPP and show the location on the site map
- Provide stockpile toe BMP when sediment is not adequately contained by another boundary BMPs. Reference other boundary BMPs managing the stockpile exposure risk.
- Ensure the workforce is informed of stockpile management requirements.

### **OPERATOR BMP MODIFICATION OR REPLACEMENT**

- Operator is invited to propose an alternative BMP or modify this preferred BMP. The proposed BMP must match or exceed performance requirements as this preferred BMP. Any deviations from this preferred BMP must be reviewed and accepted by the oversight authority.
- Submit BMP modifications or replacements to the oversight authority for review; including but not limited to; Proprietary system literature, modified illustrations, any operation procedures and maintenance adjustments, etc.

### **MAINTENANCE/MANAGEMENT**

- Ensure all other sediment control BMPs are installed, maintained and inspected throughout storage, staging, and topsoil redistribution operations.
- Train workforce when non-containment is recognized.
- If stockpile is not being actively used, cover it and/or provide containment so that runoff cannot enter sensitive areas, waters of the state, or storm water conveyances.

### **PERFORMANCE:**

Successful stockpile management occurs when:

- Storage areas are noted on the SWPPP documentation and are up to date
- Stockpiles are covered and/or contained with little to no contaminated runoff leaving the area

### **REFERENCE:**

- CGP 2.2.8 7.3.3
- CPP 2.2.5, 7.3.3, 2.2.14

## **BMP 36 - Construction Dewatering Retention**

### **APPLICATION**

- Project where waterline system commissioning is necessary
- A DEQ Dewatering permit is not required when full retention is provided onsite. Note, groundwater warranted dewatering operations usually do not qualify for a DEQ Dewatering Permit waiver. The exposure period and amount of groundwater results in uncertain volume calculations.

### **INSTALLATION/USE PROCEDURES**

- Provide a retention location on BMP map.
- Provide a simple detail of retention pond and operation volume necessary for full retention of anticipated dewatering volume. Attached copy of volume calculations to this BMP.
- Ensure the workforce is informed of the CGP dewatering BMP requirements.

### **OPERATOR BMP MODIFICATION OR REPLACEMENT**

- Operator is invited to propose an alternative BMP or modify this preferred BMP. The proposed BMP must match or exceed performance requirements as this preferred BMP. Any deviations from this preferred BMP must be reviewed and accepted by the oversight authority.
- Submit BMP modifications or replacements to the oversight authority for review; including but not limited to; Proprietary system literature, modified illustrations, any operation procedures and maintenance adjustments, etc.

### **MAINTENANCE/MANAGEMENT**

- Inspect following dewatering operation and ensure volume exists for any subsequent dewatering operations.
- Train workforce when non-containment is recognized.

### **PERFORMANCE:**

- Any uncontained dewatering volume constitutes BMP failure.

### **REFERENCE:**

- CGP 1.2.2, 1.2.4, 2.3.7, 7.3.4
- CPP 1.2.4, 2.2.7

## **BMP 37 - Construction Dewatering Water Truck**

### **APPLICATION**

- Project where waterline system commissioning is necessary
- A DEQ Dewatering permit is not required when dispersing water onsite. Note, groundwater warranted dewatering operations usually do not qualify for a DEQ Dewatering Permit waiver. The exposure period and amount of groundwater results in uncertain volume calculations.

### **INSTALLATION/USE PROCEDURE**

- Pump hyper chlorinated water to water truck and use for dust suppression. Attach operation details.
- Show dispersal areas on BMP site map. Not allowed on impervious surfaces are directly connected to inlets or other waterways
- Ensure the workforce is informed of the CGP dewatering BMP requirements.

### **OPERATOR BMP MODIFICATION OR REPLACEMENT**

- Operator is invited to propose an alternative BMP or modify this preferred BMP. The proposed BMP must match or exceed performance requirements as this preferred BMP. Any deviations from this preferred BMP must be reviewed and accepted by the oversight authority.
- Submit BMP modifications or replacements to the oversight authority for review; including but not limited to; Proprietary system literature, modified illustrations, any operation procedures and maintenance adjustments, etc.

### **MAINTENANCE/MANAGEMENT**

- Train workforce when non-containment is recognized.

### **PERFORMANCE:**

- Any uncontained dewatering volume constitutes BMP failure.

### **REFERENCE:**

- CGP 1.2.2, 1.2.4, 2.3.7, 7.3.4
- CPP 1.2.4, 2.

## **BMP 38 - Construction Dewatering DEQ Permit Required**

### **APPLICATION**

- Projects where groundwater is anticipated or other dewatering operation volumes would exceed available space for onsite retention.
- Project where pressure system and waterline commissioning is necessary
- Projects where groundwater warranted dewatering operations are anticipated.

### **OPERATION PROCEDURE**

- Provide dewatering operation location(s) on BMP map.
- Attach a copy of the DEQ Dewatering Permit to this BMP.
- Attach a copy of all permit required inspection, monitoring requirements, operator prepared BMPs or proprietary systems and chemical treatment methods.
- Ensure the workforce is informed of the DEQ permit dewatering BMP requirements.

### **OPERATOR BMP MODIFICATION OR REPLACEMENT**

- Operator is invited to propose an alternative BMP or modify this preferred BMP. The proposed BMP must match or exceed performance requirements as this preferred BMP. Any deviations from this preferred BMP must be reviewed and accepted by the oversight authority.
- Submit BMP modifications or replacements to the oversight authority for review; including but not limited to; Proprietary system literature, modified illustrations, any operation procedures and maintenance adjustments, etc.

### **MAINTENANCE/MANAGEMENT**

- Ensure proprietary system, inspection, monitoring maintenance and application methods are followed.
- Train workforce when non-containment is recognized.

### **PERFORMANCE:**

- Any uncontained dewatering volume constitutes BMP failure.
- Any DEQ Dewatering Permit non-compliance.

### **REFERENCE:**

- CGP 1.2.2, 1.2.4, 2.3.7, 7.3.4
- CPP 2.2.3